



SPN
SLO-PITCH NATIONAL



OFFICIAL SLO-PITCH RULES
2016

www.slo-pitch.com

\$8.00
Printed in Canada

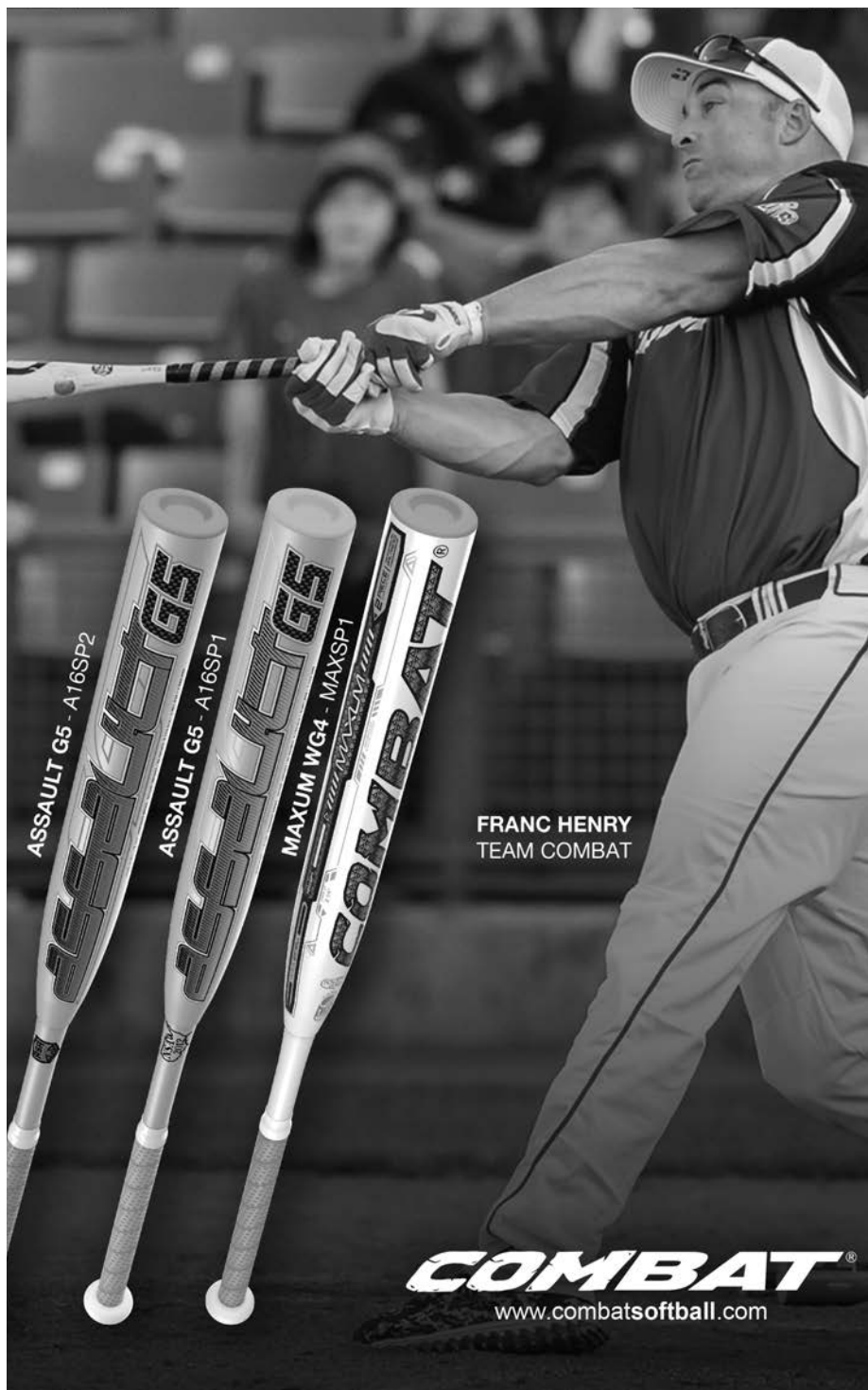

ASSAULT G5 - A16SP2

ASSAULT G5 - A16SP1

MAXUM WG4 - MAXSP1

FRANC HENRY
TEAM COMBAT

COMBAT[®]

www.combatsoftball.com



NEVER SETTLE®
NEVER SETTLE.

INSTAGRAM @MIZUNO_BASEBALL_CAN
FACEBOOK.COM/MIZUNOCANADADIAMOND

SPN
SLO PITCH NATIONAL



MAKE THE CALL

Become a registered Umpire this season
For more information, call 416-674-1802
or contact spn@slo-pitch.com

SLO-PITCH NATIONAL SOFTBALL INC.



THE OFFICIAL 2016 SLO-PITCH SOFTBALL PLAYING RULES

Copyright Slo-Pitch National Softball Inc. - 2016

SLO-PITCH NATIONAL STRONGLY RECOMMENDS THAT THIS RULE BOOK BE READ IN DEPTH.

Slo-Pitch National Softball Inc. retains the right to amend any rule in this book at any time. Any new rules or rule revisions shall be announced and posted at www.slo-pitch.com.

Slo-Pitch National encourages all members to submit recommended changes for consideration.

Any recommendations must be received by the Regional Director in writing by August 5, 2016, in order to be addressed at the 2016 Annual General Meeting.

NOTE: This Rule Book governs National Championships and Slo-Pitch National does **NOT** dictate that leagues or tournament conveners follow these rules. The Rules were revised by the Slo-Pitch National Officiating Committee to ensure safety of all participants as the foremost priority. Slo-Pitch National strongly recommends the use of this Rule Book at all levels.

**INSURED MEMBER LIABILITY COVERAGE MAY BE
JEOPARDIZED BY NON-COMPLIANCE WITH THESE RULES.**

All participants registered with Slo-Pitch National shall be considered members. All members agree, through participation, to accept the rules set forth by Slo-Pitch National in this rule book. Members who fail to adhere to the conduct of members outlined at www.slo-pitch.com may have penalties and/or suspensions rendered against them as per the the STG&OR section of this rulebook.

Note: Use of the word "he" in this publication is intended to include both masculine and feminine genders unless otherwise noted.

TABLE OF CONTENTS

	PAGE
INTRODUCTION	1
TABLE OF CONTENTS	2
INDEX TO RULES	3-5
RULE 1 - THE PLAYING FIELD	6-8
RULE 2 - EQUIPMENT	9-12
RULE 3 - DEFINITIONS	13-19
RULE 4 - THE GAME	20-21
RULE 5 - PLAYERS, SUBSTITUTES AND RE-ENTRY	22-24
RULE 6 - PITCHING	25-26
RULE 7 - BATTING	27-30
RULE 8 - BASERUNNING	31-37
NATIONAL CHAMPIONS - 1990-2015	38-40
NATIONAL CHAMPIONSHIP LOCATIONS 2016/2017	41
RULE 9 - BALL IN PLAY (ALIVE) & DEAD BALL	42-43
METRIC CONVERSIONS	43
RULE 10 - UMPIRES	45-49
RULE 11 - SCORING	50-53
RULE 12 - YOUTH PROGRAM	54
RULE 13 - COED PROGRAM	55-56
RULE 14 - MASTERS/SENIORS PROGRAM	57
SANCTIONED TOURNAMENT GUIDELINES AND OPERATING RULES (STG&OR)	58-63
SLO-PITCH NATIONAL PERSONNEL	64-72
WHAT DOES SPN HAVE TO OFFER	74-75
SPN INSURANCE PROGRAM	76
SLO-PITCH NATIONAL HALL OF FAME	77



www.slo-pitch.com
spn@slo-pitch.com

INDEX TO RULES

References are to Rule, Section and Article

AGE – Masters/Seniors	14-1	BATTER'S AREA.	7-3, 7-6
Minimum	STG&OR-2A-C	dimensions	1-5
Umpire	10-2B	definition	3-11
ALTERED BAT - definition	2-1-H, 3-1	BATTING	Rule 7
use of	7-3, M	BATTING ORDER.	5-3C, 7-1, 7-2
APPEAL PLAY – definition.	3-2	definition	3-12
alive ball.	6-8	Coed.	13-1
dead ball.	6-9	BENCH OR DUG-OUT – definition.	3-13
BALL – official.	2-2	BLOCKED BALL – definition	3-14
definition	3-3	baserunner advances	8-7, C, G
when called	7-7	BLOOD RULE.	5-8
umpire's signal	10-11, D	Umpire	10-3, N
BASE – dimensions.	2-4	BOUNDING BALL – definition.	3-15
definition	3-4	BUNT – definition.	3-16
double.	2-5	called out	7-3, C
order	8-1, 8-5, 8-8A, 8-9A, C, 9-2, O	umpire calls	10-5, D, G
dislodged	8-8C, 9-2, R	CALLED GAME – definition 3-17, 4-4C, D, 4-5C	
BASE ON BALLS – definition.	3-5	CATCH – definition.	3-18
batter awarded.	8-3, A	CATCHER'S AREA – dimensions.	1-7
intentional walk – signal	10-11, E	definition	3-19
BASE PATH – definition.	3-6	catcher's position	5-2, A, 6-5C
running out of.	8-4, G, 8-5, O	CHARGED CONFERENCES	
ball in play	9-2 S	definition	3-20
BASERUNNING	Rule 8	defensive	6-10
BASERUNNER – definition	3-7	offensive	7-12
ball in play	8-4, 8-5, 9-2, M, O, P-T	number allowed	8-13
Coed.	13-4	CHOPPED BALL – definition	3-21
lead-off.	8-5, Q, R, T, 10-4, B	called out	7-3, C
leaves field of play	8-9 A, D	umpire calls	10-5, D, G1
return to their base.	8-10	COACH – definition.	3-22
BASE STEALING	8-11	conduct.	5-9, 5-10
BASE UMPIRE	10-4, 10-6	conference	7-12
BAT – official	2-1	interference.	8-5, F, J, K
BATTED BALL – definition.	3-8	COACH'S BOX – dimensions.	1-11
batting	7-6, 7-8, 7-9, 7-10	definition	3-23
ball in play	9-2, C, D, I, K-M	COED PROGRAM	Rule 13
dead ball.	9-3, T	COMMITMENT LINE	1-9, 8-14, 13-4C, 14-3C
touches batter.	8-4A, 9-3H, 10-5, G3	definition	3-24
BATTER - definition	3-9	COURTESY RUNNER	8-15
in the batting area	7-3, 7-4, 7-6, 7-7	Coed	13-4, G
awarded 1st base.	8-3	Masters/Seniors	8-15, 14-2
ball in play	9-2, C	DEAD BALL	9-3
batter is out	7-3	definition	3-25
called out if.	9-3, F, G, H, J	appeals.	6-8, 6-9
BATTER-BASERUNNER	8-2, 8-4	delayed dead ball definition	3-27
called out	8-4	delayed dead ball signal.	10-11, M
definition	3-10		

DEFENSIVE TEAM – definition	3-26	Master's Seniors	14-4
positions	5-2, 5-5	National Champ	STG&OR – 3L – M
DEFINITIONS	Rule 3	HOME TEAM – definition	3-40
DIAMOND – dimensions	1-2, 1-3	ILLEGAL BAT	7-3B, 9-3F
DOUBLE BASE	2-5	definition	2-1I, 3-4I
baserunner out	8-4L	ILLEGAL PITCH – definition	3-42
definition	3-28	ILLEGAL PITCHING ACTIONS	6-7
DOUBLE PLAY – definition	3-29	ball is called	6-7 Eff
EQUIPMENT	Rule 2	dead ball	9-3, B
on field	2-10	umpire called	10-4, A
safety standards	2-11, STG&OR – 10	ILLEGALLY BATTED BALL	
FAIR BALL – definitions	3-30	definition	3-43
legally batted	7-8, 7-9, 8-2, 8-3, 8-4, 8-6	batter out if	7-3, A
in play	9-2	dead ball	9-3F
umpire's signal	10-11-I	ILLEGALLY CAUGHT BALL	7-4
FAIR TERRITORY – definition	3-31	definition	3-44
FAKE TAG – definition	3-32	batter/baserunner	8-6H
FIELDER – definition	3-33	umpire call	10-4, F
appeals	6-8, 6-9	ILLEGAL PITCHED BALL	7-7
illegal glove	7-4	ILLEGAL RE-ENTRY	5-7 Eff
put batter out	7-3, H, J, L, O 8-4	ILLEGAL SUBSTITUTION	5-7 Eff
put runner out	8-5	IN FLIGHT – definition	3-45
FLY BALL – definition	3-34	IN JEOPARDY – definition	3-46
intentional drop	7-3, H	batter/baserunner	8-2
legally caught	7-3, N	baserunner	8-6, 8-9
ball in play	9-2, F	INFIELD – definition	3-47
FORCE OUT – definition	3-35	INFIELD FLY – definition	3-48
by fielder	8-5, N	batter out	7-3, P
FORFEITED GAME	4-9	ball in play	9-2, G
FOUL BALL - definition	3-36	plate umpire's call	10-5, G 2
batter out if	7-3, D	umpire's signal	10-11, R, S, T
legally batted	7-9	INNING	4-4
dead ball	9-3, I	definition	3-49
umpire's signal	10-11, G	INTENTIONAL WALK – definition	3-50
FOUL TIP	7-10	pitcher tells umpire	8-3, B
definition	3-37	umpire's signal	10-11, E
umpire's signal	10-11, H	INTERFERENCE – definition	3-51
FOUR BASE AWARD	7-11B, 8-7, A2	distracted batter	5-5
definition	3-38	batter/baserunner	7-3F, 8-4, G, I, J
umpire's signal	10-11, Q	baserunner	7-3J, 8-5, F-H
GAME	Rule 4	physical/verbal	3-51, 8-4 J, 8-5 B
GLOVE	2-6	player	7-3G, 7-5D, 8-5L, 9-3L
illegal glove	7-4	coach	8-5J, K, 9-3, Q
HELMET	2-8B	spectator	3-51, 7-3L, 9-3, S
HOME PLATE – placement and use	1-4	LEGAL CATCH – definition	3-52
dimensions, the original home plate	2-3A	LEGAL SWING – definition	3-53
the home plate / strike mat	2-3B	LEGALLY DELIVERED PITCHES	6-4
batter steps across	7-3, E	LINE DRIVE – definition	3-54
as base	8-1	dropped	7-3, H, 9-3, K
baserunner is out	8-4H, I, 8-5L, V, 8-14	LIVE BALL	9-2
HOME RUN	8-7A	definition	3-55
definition	3-39	time-out requests	10-12 G
umpire's signal	10-11, P		
HOME RUN RULE	7-11		

MANAGER – definition	3-56	PROTEST	STG&OR – 4
making substitution	5-6 A	QUICK PITCH – definition	3-72
batting order	5-3 D, 5-7B, 7-2	no pitch	6-11
violation of rules	10-4 C	REGULATION GAME	4-4
advise umpire of changes	10-5, I	RE-ENTRY INTO GAME	5-7
interference	9-3, O	RE-TOUCH – definition	3-73
charged conference	3-20, 6-10, 8-13	ROUND ROBIN FORMAT	STG&OR – 5
MASKS	2-8A	RUNS	4-6, 4-7, 4-8
MASTERS/SENIORS PROGRAM	Rule 14	SACRIFICE FLY – definition	3-74
MERCY RULE	4-4, E	SCORING	Rule 11
definition	3-57	SCORING LINE . 1-10, 8-5V, 8-14, 13-4E, 14-3E	
NATIONAL CHAMPIONSHIPS	STG&OR – 3	definition	3-75
NO PITCH	6-5	SENIORS	Rule 14
quick pitch	6-11	courtesy runner	8-15, 14-2
OBSTRUCTION – definition	3-58A	SHOES	2-7
ball in play	9-2, N	STRIKE – called	7-6
baserunner	8-7, E	umpire's signal	10-11, C
dead ball	9-3, V, 10-5F	SUBSTITUTIONS	5-6, 5-7
verbal	3-58A	SUSPENDED GAME	STG&OR – 6
OFFENSIVE TEAM – definition	3-59	definition	3-76
ON DECK BATTER	7-5	umpire stops game	4-10
ON DECK CIRCLE – dimensions	1-6	TAG – definition	3-78
definition	3-60	TEAM	5-1, 5-3, 5-4
OPEN INNING – definition	3-61	ratings	STG&OR – 7
OPTION PLAY	7-4, 8-3 E	THREE FOOT LINE – definition	3-79
definition	3-62	placement of	1-8
OUTFIELD – definition	3-63	batter out	8-4G
positions	5-2	THROW – definition	3-80
OVERSLIDE – definition	3-64	TIEBREAKER	4-4 B
put out	8-4F, 8-8	definition	3-81
OVERTHROW	8-7G	TIME or TIME OUT – definition	3-82
definition	3-65	ball is dead	9-3, U
PENALTIES, SUSPENSIONS & EJECTIONS.		umpire calls	10-4, D, 10-12, B, E, F
	STG&OR – 1	umpire signal	10-11, L
PITCHER/INFIELDER – definition	3-66	TRAPPED BALL – definition	3-83
pitching rules	6-1-7, 6-11, 1-7	TRIPLE PLAY – definition	3-84
position	5-2	TURN AT BAT – definition	3-85
PITCHING	Rule 6	UMPIRES	Rule 10
PITCHING ZONE	1-12	ball in play/dead ball calls	9-1-3
definition	3-67	eligibility	10-2
position of pitcher's feet	6-2	National Championships	STG&OR – 9
PIVOT FOOT – definition	3-68	UNLIMITED BATTING ORDER	5-3
PLAY OR PLAY BALL – definition	3-69	definition	3-86
umpire call	9-1	batting	7-1
umpire signal	10-11, A	Coed	13-1
PLAYER ELIGIBILITY	STG&OR – 2	UNIFORMS	2-9
PLAYER IDENTIFICATION	STG&OR – 1, 2	National Championships	STG&OR – 8
PLAYER POSITIONS	5-2	UNSPORTSMANLIKE CONDUCT	
PLAYING FIELD	Rule 1, 1-1	(see also "Interference")	5-5, 5-10
dimensions	1-4	WALK – definition	3-87
definition	3-70	Coed	13-3
PROFANITY – definition	3-71	WILD THROW – definition	3-88
batter is out	7-3 R	WINNER OF GAME	4-5
batter-baserunner is out	7-3R, 8-4 M	YOUTH PROGRAM	Rule 12
baserunner is out	7-3R, 8-5 X		
PROTECTIVE EQUIPMENT	2-8		

RULE 1. - THE PLAYING FIELD

Sec. 1 THE PLAYING FIELD is the area within which the ball may be legally played or fielded. The field shall have a clear and unobstructed area within an established minimum radius from Home Plate to the furthest boundaries between the foul lines. Outside the foul lines, between the foul lines and the backstop or other field limitations, there shall be an unobstructed area of not less than 25 feet in width.

NO MAXIMUM DISTANCE SET FOR THE FENCE.

Sec. 2 RECOMMENDED DIMENSIONS OF A SLO-PITCH FIELD:

This diagram is the recommended dimensions for a slo-pitch field.

The recommended distance to the fence is a minimum 300 feet for Men and 225 feet for Women.

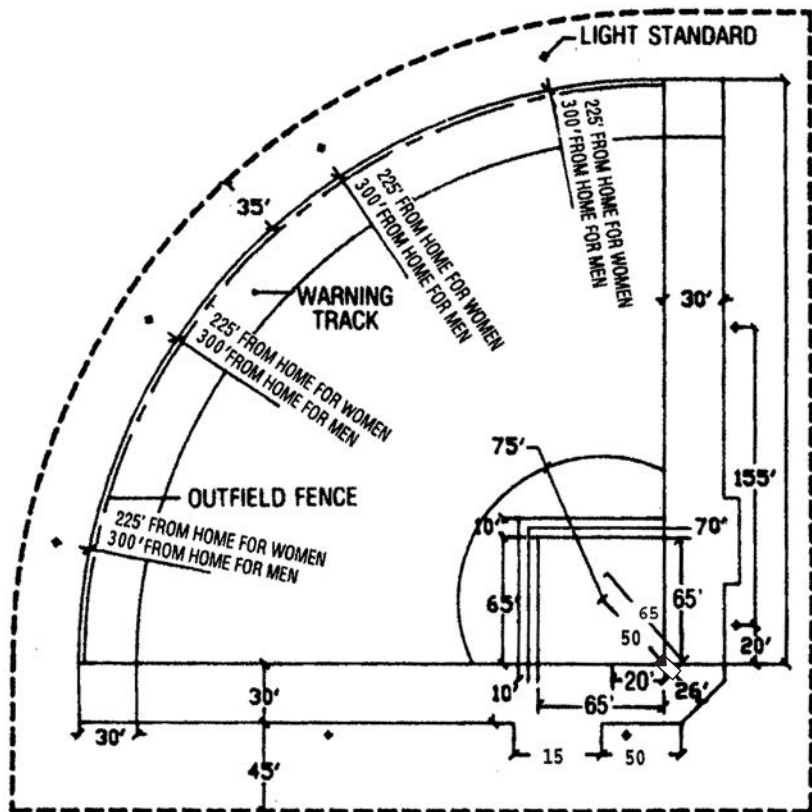

Sec. 3 THE OFFICIAL DIMENSIONS of the DIAMOND shall be:

- A. Baselines of 65 feet for Mens, Womens, Coed, Masters and Seniors. The baselines for Mens A and Mens B categories shall be 70 feet.
- B. Pitcher's distance shall be a zone of 24" wide from 50-65 feet for Mens, Womens, Coed, Masters and Seniors. These dimensions are for games using the 11 and the 12 inch ball.

Sec. 4 THE LAYOUT OF THE FIELD is shown in the accompanying diagram. First select the desired location of home plate, then drive a stake in the ground which will establish the rear corner of home plate (corner number "3"). Fasten cord to this stake and tie knots at distances of 50, 65, 70, 91' - 11", 99', 130 and 140 feet for Mens, Womens, Coed, Masters and Seniors. Place this cord along the direction line, which will be towards centre field and at the 50 foot marker place a stake, which will be the middle of the front edge of the pitching zone. Further along this cord drive a stake at the 65 foot marker, which will be the back of the pitching zone. Further along this cord drive a stake at the 91 foot, 11 inches or 99 foot mark which will be the middle of second base, then release that knot and pick up the one at 130 or 140 foot mark and fasten it at the second base stake. Then take the cord at the 65 or 70 foot marker and walk to the right until the cord is taut, both from second to first base and from home to first, then drive a stake which will mark the outside corner (outfield/foul corner) of the first base side foul line. Again between second, third and home, drive a stake which will then establish the outside corner (outfield/foul corner) of third base, with the line between home and third, becoming part of the third base side foul line. Both the first and third base foul lines shall be extended to the far extremities of the field. Once the lines have been drawn on the field, using the original home plate as reference, place the home plate / strike mat over the top of the existing plate, with the leading edge of the strike mat (22") facing the pitcher, squarely and completely, covering the leading edge of home plate.

OFFICIAL DIMENSIONS FOR SLO-PITCH DIAMONDS:

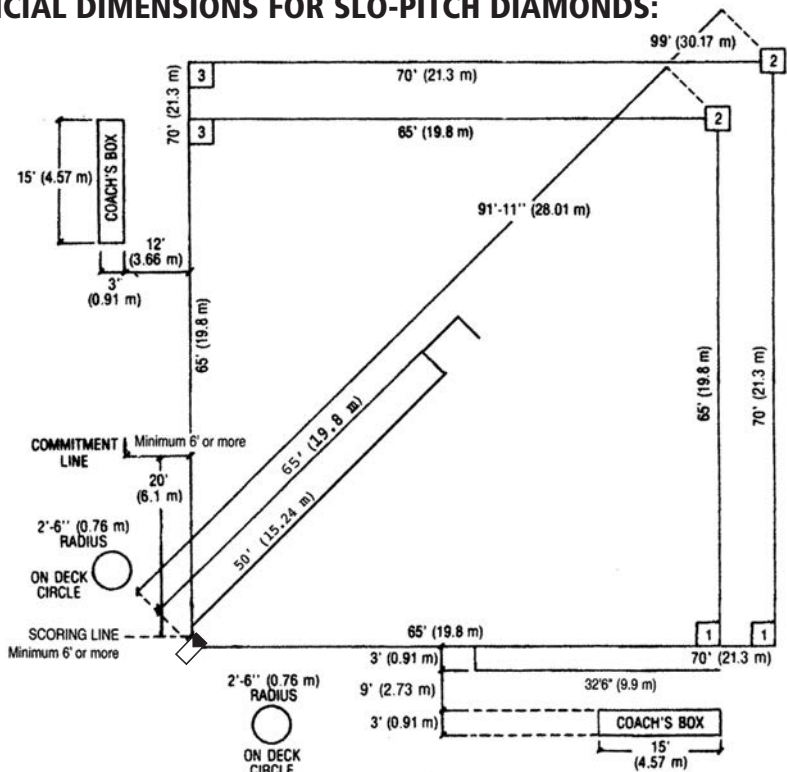

- Sec. 5 THE BATTER'S AREA** is an area adjacent to and on either side of the home plate / strike mat.
- Sec. 6 ON DECK CIRCLES** shall be a 5 foot circle (2-1/2 foot radius), placed adjacent to the end of the team's bench or dugout area closest to the home plate / strike mat.
- Sec. 7 THE CATCHER'S AREA** is an area behind the home plate / strike mat.
- Sec. 8 THE THREE FOOT LINE** is drawn outside of and parallel to the first base foul line, starting at the outside corner (outfield/foul corner) of first base and extending 32 feet 6 inches toward the original home plate.
- Sec. 9 THE COMMITMENT LINE** is drawn 20 feet from corner "1" of the original home plate (corner closest to third base) and perpendicular to the third base line and shall extend a minimum of 6 feet or more from the baseline into foul territory (in all divisions and categories).
- Sec. 10 THE SCORING LINE** is drawn from corner "1" of the original home plate (corner closest to the third base) and perpendicular to the third base line and shall extend a minimum of 6 feet or more from the base line into foul territory (in all divisions and categories).
- Sec. 11 THE COACHES' BOXES** shall be marked in at first and third bases. The boxes shall be 15 foot by 3 foot rectangles. The lines shall be 12 feet from and parallel to the foul lines and shall start at the outside (outfield/foul) corners of the bases and extending toward the original home plate.
- Sec. 12 THE PITCHING ZONE** is a zone 24" wide located 50 to 65 feet from the original home plate. A Pitcher may choose to pitch from anywhere within this zone. If a pitching rubber is present, it is recommended that the rubber be placed or marked at 65 feet and not 50 feet.

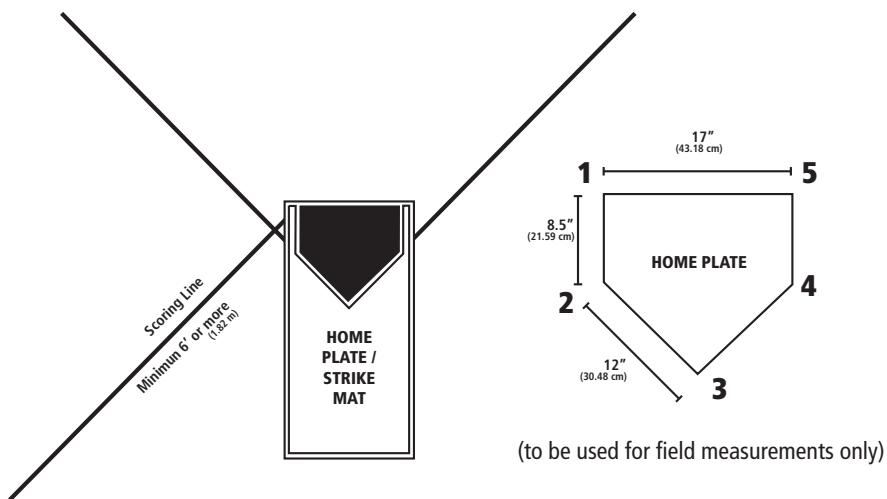

RULE 2. - EQUIPMENT

Sec. 1 THE OFFICIAL BAT shall be round or three sided and measure not more than 34 inches long and not more than 2-1/4 inches in diameter at its largest part and its weight shall not exceed 38 ounces. The bat shall have a safety grip of cloth tape, cork or some other composite material to facilitate holding the bat. The safety grip shall not be less than 10 inches long, nor extend more than 15 inches from the small end of the bat.

- A. The bat, if made of hardwood, shall be in one piece, laminated from sections of hardwood bonded together with adhesive in such a way that the grain directions of all the pieces are essentially parallel to the length of the bat.
- B. The bat may also be made of aluminum or other metal tubing, ceramic, fiberglass, graphite, bamboo or be a composite bat.
- C. The angular-handled and water-filled bats are legal, as are the bats with oval shaped handles.

EFFECT Sec. 1 A-C When a bat DOES NOT meet specifications as defined, has flat spots or pronounced dents, or , if in the umpire's judgement the bat has been tampered with, the umpire shall remove the bat from the game.

- D. The official bat must be made with a solid handle, which is not necessarily made of the same material as the rest of the bat, and may also have an insert at the barrel end. It must conform to the same dimensions of length, weight and diameter as relates to hardwood bats. The knob portion must be welded, or mechanically attached to the bat by the manufacturer. A manufactured composite bat is considered a legal bat and must conform to the same dimensions of length, weight and diameter as relates to hardwood bats.
- E. Authorized bat manufacturers shall mark their products with "OFFICIAL SOFTBALL" or words to that effect.
- F. Warm-up bats must be of one piece construction and must have a safety grip. The bat must be marked "OFFICIAL WARM-UP BAT". One or two official softball bats or one warm-up bat or one warm-up bat and one official softball bat may be used for purposes of warming-up in the on deck circle. Nothing may be attached to a bat such as a do-nut, fan, etc., when loosening up.
- G. Pine tar or any other type of adhesive substance is allowed to be used by a batter as long as there are no markings from this substance beyond the 15 inch legal taping.
- H. An altered bat is a bat that has had its physical structure changed in such a way to improve the distance factor or cause an unusual reaction on the ball. For example: replacing a metal bat handle with a wooden or other type of handle or inserting material inside the bat.
- I. A bat may be painted at the top or bottom, or engraved on the barrel with the player's initials for identification purposes only.
- J. It is the responsibility of all players to know whether their bat has been altered or is on the non-approved bat list. If a bat is not listed on the approved or non-approved bat list, then it shall be considered a non-approved bat.

NOTE: The updated bat policy is available on the Slo-Pitch National website (www.slo-pitch.com)

NON-APPROVED BATS: The batter is out and ejected from the game if he enters the batter's area with an illegal bat (see non-approved list). In addition, the coach/manager is ejected as well.

ALTERED BATS: Any player who is found playing with an altered bat will be suspended for a minimum of 3 years from SPN sanctioned events. Any altered bat found before the start of the game, and if the SPN representative cannot establish who the owner of the altered bat is, then the coach/manager will be suspended for a minimum of 3 years from SPN sanctioned events. SPN will not be responsible for any problems of any nature whatsoever caused by the use of non-approved and/or altered bats.

Sec. 2 THE OFFICIAL BALL * to be used shall be:

	11"	12"
Core Material	Polyurethane	Polyurethane
Cover	Protac	Protac
Thread	Waxed Cotton	Waxed Cotton
Stitch Count	Minimum 88	Minimum 88
Construction	Composite Laminate Design	Composite Laminate Design
Cover Separation Force	20 ft. lb/second	20 ft. lb/second
Finished Size	10 7/8" – 11 1/8"	11 7/8" – 12 1/8"
Finished Weight	5 1/2 oz. – 6 1/2 oz	6 oz – 7 oz

*The ball must have Slo-Pitch National approval.

The internal composition of the core must be clearly imprinted on the ball.

The Official Softball, approved and recommended by SPN is the Worth Softball.



Sec. 3A THE ORIGINAL HOME PLATE shall be made of rubber or other suitable materials. It shall be a five sided figure, 17 inches across the front edge of the plate facing the pitcher. The sides shall be parallel to the inside of the batters' boxes and shall be 8 1/2 inches long, extending forward toward the pitcher's plate from either base line. The sides of the plate, from the rear corner (corner "3" – see diagram), along with the base line, shall be 12 inches long, set wholly within the base lines, where they form a square angle, with the point (corner "3") pointing towards the catcher. Home plate is always a part of fair territory. The black border, if applicable, that outlines the plate is NOT to be considered as part of home plate. The home plate is to be used only for marking the field with the playing lines.

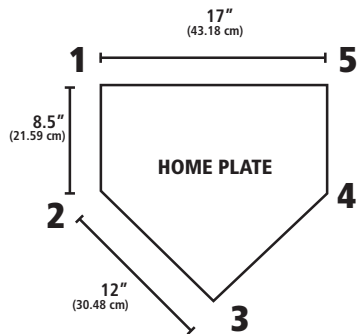

Sec. 3B THE HOME PLATE / STRIKE MAT

shall be made of rubber or other suitable materials. It shall be a rectangle, 22" wide by 40" long. A representation of a home plate may be drawn on the mat, with the leading edge of the illustration equal to the leading edge of the mat. The sides shall be parallel to the inside of the batter's area, extending forward, toward the pitcher's plate from either base line. The original home plate is to be used only for marking the field with the playing lines.

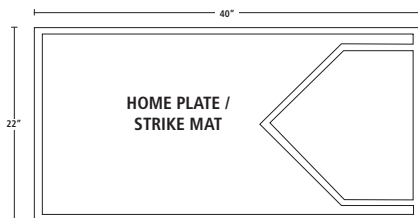

Sec. 4 THE BASES other than the home plate / strike mat and first base (where a double base is used - see Rule 2 - Sec 5 - Double Base) shall be 15 inches square and not more than 5 inches in thickness. They shall be made of canvas, plastic or other suitable materials, filled with soft padding. They shall be WHITE in colour. **All white bases are located entirely within fair territory.** All BASES must be securely fastened at their designated places. The entire home plate / strike mat is considered to be fair territory.

Sec. 5 A DOUBLE BASE is mandatory for use at first base. This one-piece base shall be 15 inches by 30 inches and shall be made of canvas, plastic or other suitable material, filled with soft padding and not more than 5 inches in thickness. One half of the base is white and is to be **securely fastened** in fair territory and the other half is orange and is to be securely fastened in foul territory. The following rules apply to the Double Base:

- A. If a batted ball hits ANY PART of the white portion, it is a fair ball and if it hits COMPLETELY on the orange portion, it is a foul ball.
- B. If a play is made to first base, the batter-baserunners first attempt to reach first base must be to touch some portion or all of the orange base. If he touches only the white base in these situations, he is to be called out.
- C. A defensive player must use only white or some portion of it at all times. If he touches only the orange, it is the same as not touching the white at all: missed base.
- D. If the batter-baserunner touches on all of or part of the orange base and a portion of the white, it is a legal touch, or, if the defensive player touches a portion of the white and a part of the orange, it is a legal touch.
- E. Once a batter-baserunner has attained first base, and time is called, he must use only the white portion of the base. This includes:
 1. After over-running first base, or after rounding first base, if applicable, and the baserunner decides not to advance further, he must return to the white portion.
 2. After over-running first base, or after rounding first base, if applicable, and the baserunner touches only the orange portion and decides to advance further, he need not retouch the white portion.
 3. When tagging up, the baserunner must use the white portion.
 4. When there is an attempted pick-off play, the baserunner must return to the white portion.

EFFECT Sec. 5 E 1-4 If the baserunner uses only the orange portion at any time after the first attempt at first base and is not in contact with any part of the white portion, then he is considered to be out of contact with the base and is to be called out if tagged or leads off.

Sec. 6 LEGALLY ADOPTED GLOVES may be worn by any fielder.

- A. Pitchers, catchers and first basemen may wear a glove or mitt of any size, including a “trapper” style glove. All other players are restricted to a three (3) or four (4) finger type glove. The webbing shall not be constructed to form any type of net or tray.
- B. Multi-coloured gloves are legal.

Sec. 7 A SHOE shall be considered legal if it is made with either leather or canvas uppers or similar materials. The soles may have soft or hard rubber cleats or replaceable cleats, provided they meet all the legal requirements. The use of shoes with metal cleats, exposed metal, or toe pieces is PROHIBITED. Shoe sole or heel projections other than the standard shoe plate are prohibited. The all-purpose molded plastic cleat softball shoe is legal. Shoes must be worn by all players and coaches on the diamond.

EFFECT Sec. 7 If a player or coach is found to be wearing illegal shoes, he is to be ejected from the game.

Sec. 8 PROTECTIVE EQUIPMENT

Any player who has a concern about an injury occurring from being struck with a ball during SPN sanctioned play should address that concern by the use of protective equipment which is available and is allowed in Slo-Pitch National sanctioned play.

A. MASKS: It is strongly recommended that masks and body protectors be worn by catchers.

B. HELMETS: SPN strongly recommends that CSA approved protective headwear be used by all batters and baserunners in any SPN sanctioned tournament or event.

NOTE: For safety reasons, it is strongly recommended that all protective equipment be worn by appropriate players.

Sec. 9 UNIFORMS, including similar head pieces or caps, when required, shall be of similar colours and materials. MINIMUM uniform is considered to be matching tops.

- A. All those participating in a game shall wear the adopted TEAM UNIFORM, including shoes, **and shall wear it properly.** Managers and coaches, when on the field, shall wear the adopted full uniform, shoes and if appropriate, jacket, which includes the team’s emblem and colours, which can readily identify them as a member of a team.

EFFECT Sec. 9A The player, coach or manager shall be asked to dress properly. If they refuse they will be ejected from the game.

- B. Refer to “Sanctioned Tournament Guidelines and Operating Rules” for uniform requirements for National Championships.

- C. Exposed metal braces are prohibited. Casts are prohibited, even if covered. Metal braces worn as a preventative aid must be covered with soft, pliable material.

Sec. 10 EQUIPMENT shall not be allowed to remain on the playing field, during the playing of the game, either on fair or foul territory.

EFFECT Sec. 10 If after one warning, which will be given to the coaches of both teams simultaneously, there is still equipment left on the playing field, the offending coach will be ejected from the game.

Sec. 11 EQUIPMENT: Slo-Pitch National reserves the right to disapprove any equipment due to the failure to meet either CSA Safety Standards or safety standards as set by the Slo-Pitch National Officiating Committee.

RULE 3. - DEFINITIONS

Sec. 1 AN ALTERED BAT is a bat that has had its physical structure changed in such a way to improve the distance factor or cause an unusual reaction on the ball. For example: replacing a metal bat handle with a wooden or other type of handle, inserting material inside the bat.

Sec. 2 APPEAL PLAY is a live or dead ball play which the umpire cannot rule upon until a decision is requested by the defensive or offensive team. The appeal must be made before the next legal or illegal pitch, intentional walk, or before all defensive players have left fair territory. Types of appeal plays include missing a base, leaving a base on a caught fly ball before the ball is first touched, batting out of order, illegal substitution, and illegal re-entry.

Sec. 3 BALL is a pitched ball that does not touch any part of the home plate / strike mat, or conform to the legally delivered pitch rules, and is not struck at by the batter.

Sec. 4 BASE is one of the three stations, along with the scoring line, which must be touched by a runner, in accordance with the rules that follow, to legally score a run.

Sec. 5 BASE ON BALLS permits a batter to gain first base, without liability to be put out and is awarded by the umpire when four pitches are called balls or an intentional walk is awarded.

Sec. 6 BASE PATH is an imaginary line three feet to either side of a direct line between two bases.

Sec. 7 BASERUNNER OR RUNNER is a player of the team at bat, who has hit a fair ball and obtained first base, or who has been awarded first base for any reason, before he is put out.

Sec. 8 BATTED BALL is any pitched ball that is hit by the bat, or that hits the bat, thus becoming either a fair or foul ball. No intent to hit the ball is necessary.

Sec. 9 BATTER is the offensive player who takes a position in the batter's area for the purpose of hitting the ball.

Sec. 10 BATTER-BASERUNNER is the term that identifies the offensive player who has just hit the ball, and applies until he is either put out prior to first base, or until the play on which he becomes a baserunner is complete.

Sec. 11 BATTER'S AREA is that area adjacent to the home plate / strike mat, within which the batter takes his position when it is his turn to bat. Prior to the pitch, he must place 1 foot on the ground anywhere in the batter's area, not more than 3 feet from the side edge of the home plate / strike mat. When striking the ball at the front of the home plate / strike mat, the trailing foot cannot be completely forward of the front edge of the home plate / strike mat. When striking the ball at the back of the home plate / strike mat, the lead foot cannot be completely behind the back edge of the home plate / strike mat.

Sec. 12 BATTING ORDER is the official listing of offensive players in the order in which they must bat. Each player's surname, given name and uniform number, must also be listed.

Sec. 13 BENCH OR DUGOUT is the seating facility reserved for team members in uniform when they are not actively participating in the game.

Sec. 14 BLOCKED BALL is a batted or thrown ball that is touched, stopped or handled by a spectator or person not engaged in or a part of the game, or that touches any object which is not part of the legal official equipment, or playing field, or which hits or goes beyond a designated out of play area.

Sec. 15 BOUNDING BALL is a ground ball.

Sec. 16 BUNT is a batted ball not swung at, but intentionally met with the bat and tapped slowly within the infield.

Sec. 17 CALLED GAME is one whereby the umpire deems it necessary to terminate any further play.

Sec. 18 CATCH is the act of a fielder receiving the ball, in flight, and having it securely in his possession, in his hand or glove. It is a legal catch provided he does not use his cap, mask, a pocket or any other part of his uniform, or the glove off the glove hand to stop or catch the ball, or he does not collide with a wall, fence, another person or fall down and as a result of any such collision, drop the ball. To establish the validity of the catch, the fielder shall hold the ball long enough so the umpire is convinced he had *complete* control of the ball and himself and that any release of the ball by him was voluntary and intentional. Dropping the ball while attempting to throw it shall not invalidate the catch.

Sec. 19 CATCHER'S AREA is that area, behind the home plate / strike mat, within which the catcher must remain while and until a pitched ball has reached or passed home plate / strike mat or is batted. If a catcher wishes to hold his glove forward and in the territory behind the home plate / strike mat, the glove must be held up in the air. If the glove is placed on the home plate / strike mat, one warning will be given. Any additional infractions will immediately be called an illegal pitch.

Sec. 20 CHARGED CONFERENCES There are two types of charged conferences. They are **DEFENSIVE** and **OFFENSIVE**

- A. A **DEFENSIVE CONFERENCE** takes place when a member of the defensive team requests "**TIME**" and a representative (not on the playing field) of that team enters the playing field and gives the umpire reason to believe that he has delivered a message (by whatever means) to the pitcher. If the representative entering the playing field removes the pitcher from the pitching position, it is a charged conference against the pitcher being removed. If this is the second charged conference, then this will result in the removal of the pitcher from the pitching position for the remainder of the game, but he can play any other position. A charged conference is not to be called if a representative from the dugout confers with a pitcher when time has been called by the umpire or an offensive conference is taking place, as long as the defensive players are all ready to play when "**PLAY BALL**" is called.
- B. An **OFFENSIVE CONFERENCE** takes place when a member of the offensive team requests "**TIME**" to allow the Manager or other Team representative to give a message to the batter or baserunner. It is not a charged conference if the batter or baserunner is substituted for when "**TIME**" is called. It is not a charged conference if an umpire initiates the time out or if the defensive team is having a conference, as long as the offensive team is ready to play when "**PLAY BALL**" is called. It is not a charged conference when a courtesy runner is put in for a runner on base.

Sec. 21 CHOPPED BALL is a ball batted whereby the batter swings the bat downward with a chopping motion with the intent that the ball bounce high into the air.

Sec. 22 COACH is a member of the team. One offensive coach only is permitted in each coach's box to direct the players of his own team while they are batting or running bases. **A defensive coach MUST be positioned outside the field of play unless he is a player-coach.**

Sec. 23 COACHES' BOXES are the areas in which the offensive coaches must stay while coaching and directing the players of their team in batting and running the bases.

Sec. 24 COMMITMENT LINE is a line drawn 20 feet from corner "1" (see diagram) of the original home plate (corner closest to third base) and perpendicular to the third base line and shall extend a minimum of 6' or more from the base line. (In all divisions and categories).

Sec. 25 DEAD BALL is any ball not in play and does not come in play again until the umpire calls "PLAY BALL".

Sec. 26 DEFENSIVE TEAM is the team whereby the players are stationed in the playing field.

Sec. 27 DELAYED DEAD BALL is a game situation in which the ball remains alive until the conclusion of a play. When the entire play is completed and "Time" is called, the umpire shall enforce the appropriate ruling.

Sec. 28 DOUBLE BASE is the base used at first base with the white portion in fair territory and the orange portion in foul territory.

Sec. 29 DOUBLE PLAY is a continuous play by the defensive team in which two offensive players are legally put out without an intervening play, or an error.

Sec. 30 FAIR BALL is a legally batted ball that settles on fair territory between the home plate / strike mat and first base, or the home plate / strike mat and third base or that is on or over fair territory, including any part of first or third bases when bounding to the outfield, or that first touches any base, or that first touches a player or umpire over fair territory, or which first touched the ground or the home plate / strike mat, or an object in fair territory or over fair territory beyond first and third bases, or that while over and above fair territory passes out of the playing field (i.e. over and beyond the outfield fence).

Sec. 31 FAIR TERRITORY is that part of the playing area within and including the first and third base foul lines from the home plate / strike mat to the bottom of the extreme playing area fence and then extending perpendicularly upwards. (The home plate / strike mat is in fair territory).

Sec. 32 FAKE TAG is an act performed by a fielder who carries out all the appropriate motions of making a tag but he does not have the ball. This will be considered obstruction and the offender may be ejected.

Sec. 33 FIELDER is any player on the team that is in the field for the purpose of playing defensively.

Sec. 34 FLY BALL is any ball batted into the air.

Sec. 35 FORCE OUT occurs when a baserunner is forced to advance to the next base due to the batter becoming a baserunner. If the baserunner (on or off the base) is tagged by a fielder with the ball or a fielder holds the ball on the base to which the baserunner is forced to advance before he reaches that base and before any succeeding runner is put out, that baserunner is considered to be forced out.

Sec. 36 FOUL BALL is any legally batted ball that stops or settles on foul territory without first being touched in fair territory, or which is first touched in foul territory, or that first touches some out of play object, or an area in foul territory, or that first touches foul ground beyond first or third base.

Sec. 37 FOUL TIP is a foul ball.

Sec. 38 FOUR BASE AWARD occurs when a fair batted fly ball deflects off a defensive player over the home run fence.

Sec. 39 HOME RUN is a fair batted fly ball that clears the home run fence before touching anything or anyone and which is not caught. This includes a ball that hits the top of the fence and bounces over.

Sec. 40 HOME TEAM is the team on whose grounds the game is being played, or if the game is scheduled on neutral grounds, it is decided by mutual agreement or toss of a coin. The home team shall be considered to be the last team at bat in each inning.

Sec. 41 ILLEGAL BAT is a non-approved bat, that does not meet specifications as outlined in Rule 2, Sec. 1. For example, a bat that is 37" long, a bat that weighs 40 ounces, a bat that is constructed of two pieces of hardwood, or a baseball bat. Painting a bat on the grip or barrel area, shall also be considered an illegal bat. A bat may be painted at the top or bottom, or engraved on the barrel with the player's initials for identification purposes only.

Sec. 42 ILLEGAL PITCH is called when the ball is pitched in such a manner that it does not conform to all of the requirements of a legally delivered pitched ball.

Sec. 43 ILLEGALLY BATTED BALL is one batted fair or foul by the batter when both of his feet are in contact with the ground, **COMPLETELY** outside the approved batter's area (rule 3 sec. 11) or when his foot is in contact with home plate / strike mat, or when the ball is batted with an illegal bat. When making contact with the ball, the batter may not place a foot on the ground completely within the 22 inch area that is the front of the leading edge of the home plate / strike mat. He may not place a foot on the ground completely within the 22 inch area that is the back of the back edge of the home plate / strike mat.

Sec. 44 ILLEGALLY CAUGHT BALL occurs when a fielder catches a batted or thrown ball with an illegal glove, or with a glove, mask, cap, or with any piece of clothing detached from its proper position on the fielder's body.

Sec. 45 IN FLIGHT describes a batted, thrown or pitched ball which is in the air and has not yet touched the ground, or some object other than a fielder.

Sec. 46 IN JEOPARDY is a term indicating that the ball is alive and in play and that an offensive player may be put out.

Sec. 47 INFIELD is that portion of the field within the baselines, and also includes the areas of the field normally covered by infielders in defensive positions.

Sec. 48 INFIELD FLY is a fairly batted fly ball (not a line drive) which can be caught by an infielder with ordinary effort when first and second, or when first, second and third bases are occupied with less than two out. Any defensive player, who positions himself within the infield area, will be considered an infielder for the purpose of this rule.

NOTE: If a fairly batted ball is to be declared an infield fly the umpire shall call: **"INFIELD FLY, IF FAIR, BATTER IS OUT"** for the benefit of the runners. Failure to make the call does not preclude the batted ball from being an infield fly. The ball is alive and if the runners advance they do so at their own risk and are in jeopardy if the ball is caught. The ruling is the same as any other caught or dropped fly ball. A foul ball is not an infield fly and if the ball falls untouched to the ground in fair or foul territory prior to first or third base and subsequently rolls into foul territory, it is just a foul ball.

Sec. 49 INNING is that portion of a game within which teams alternate on defense and offense and each half inning is terminated when 3 outs have been made.

Sec. 50 INTENTIONAL WALK is given to a batter when the pitcher advises the plate umpire that he wants to walk the batter. The umpire will then award the batter first base. An intentional walk can be granted prior to a pitch having been thrown to a batter or at any time during the batter's turn at bat. In Coed ball, if a male batter is walked, intentionally or otherwise, he will be awarded two (2) bases, and the female batter following **MUST** bat.

Sec. 51 INTERFERENCE is an act of an offensive player, team member or others which impedes hinders or confuses a defensive player while he is attempting to execute a play.

A. **Physical Interference** – occurs when an offensive player physically interferes with, impedes or confuses a defensive player while he is attempting to make a play.

B. **Verbal Interference** – occurs when an offensive player uses vocal/verbal actions that interfere with, impede, or confuse a defensive player while he is attempting to make a play.

C. **Spectator Interference** – When a spectator interferes with a player's ability to make a play.

Sec. 52 LEGAL CATCH is a fly ball caught in the glove or in the hand and is securely held, and the player is in control of the ball and himself.

Sec. 53 LEGAL SWING is one whereby the batter has attempted to hit the ball directly out to the infield or the outfield by bringing the bat through in a forward motion with a follow through, out towards the field area. A half swing or a directional partial swing is a legal swing. The "level" or upward swinging of the bat at the ball determines the legality of the swing.

Sec. 54 LINE DRIVE is a batted ball that goes in a straight line, sharply and directly into the playing field.

Sec. 55 LIVE BALL is a ball that is alive and playable and remains so until for some reason the umpire is required to call **TIME**, at which time the ball becomes dead and is not playable.

Sec. 56 MANAGER is a person appointed by the team to be responsible for the team's actions on the field, and to represent the team in communication with the umpire and the opposing team. A player may be designated as manager.

Sec. 57 MERCY RULE is a rule, whereby, when one team is winning a game by a predetermined number of runs after the prescribed number of innings have been played, the game will be stopped based on the assumption that the losing team would not be able to attain the required number of runs to win the game in the time remaining.

Sec. 58 OBSTRUCTION is the act of a fielder who is not in possession of the ball, or not in the act of fielding a batted ball, or not taking a proper position to receive a thrown ball (thrown ball must already be in flight) which impedes the progress of a baserunner who is legally running the bases. The obstruction does not have to be intentional. **Obstruction also includes the act of a defensive player who hinders the batter's ability to swing.**

A. **VERBAL OBSTRUCTION** occurs when any defensive players use vocal actions that impede or confuse a batter's ability to swing or confuse a runner.

Sec. 59 OFFENSIVE TEAM is the team at bat.

Sec. 60 ON DECK CIRCLE is the area in which the person, who is to bat next, must wait and warm-up.

Sec. 61 OPEN INNING is when a team can score as many runs as possible, before 3 outs.

- Sec. 62 OPTION PLAY** is a play whereby the manager of the offensive team has the option of taking the result of the play or having the batter go back up to bat and assume the ball and strike count he had prior to the hit.
- Sec. 63 OUTFIELD** is that portion of the field that is beyond the lines of the infield, extending to the furthest extremities of the playing field.
- Sec. 64 OVERSLIDE OR OVERSLIDING** is the act of a baserunner whose slide to a base is with such momentum that he loses contact with the base and thus is placed in jeopardy. This does not apply to the batter-baserunner as he is first approaching first base.
- Sec. 65 OVERTHROW** is a ball thrown from one fielder toward another and for whatever reason, goes into "out of play territory". If this occurs, all baserunners will be awarded two bases from the last base touched at time of the throw.
- Sec. 66 PITCHER/INFIELDER:** The pitcher becomes an infielder when after pitching the ball towards the batter he has a reasonable opportunity to field a batted ball.
- Sec. 67 PITCHING ZONE** is the area in which the pitcher must have one foot within, in order to be considered as being in the legal pitching position.
- Sec. 68 PIVOT FOOT** is the foot which when placed within the pitching zone by the pitcher, must maintain constant contact with the ground until the pitched ball is released.
- Sec. 69 PLAY OR PLAY BALL** is the term used by the umpire to indicate that play shall begin, or start up again after a dead ball situation.
- Sec. 70 PLAYING FIELD** is the area within which the game of slo-pitch is played, as established by fenced boundaries and/or boundaries determined by the league or umpire(s) as required.
- Sec. 71 PROFANITY** is the use of swear or curse words and/or severe words of contempt and disrespect.
- Sec. 72 QUICK PITCH** is a pitch made by the pitcher with the obvious attempt to catch the batter off guard and/or balance. This could be when the batter first takes his position in the batter's area and before he is ready, or when the batter is still off balance from the previous pitch.
- Sec. 73 RETOUCH** is the act of a baserunner who is returning to touch a base as legally required.
- Sec. 74 SACRIFICE FLY** is any caught fly ball that permits a baserunner to advance after a caught fly ball is first touched.
- Sec. 75 SCORING LINE** is a line drawn in foul territory starting at the corner of the original home plate closest to third base (corner "1" – see diagram pg. 8) and would run parallel to first base if the first base line was extended at the original home plate. It shall extend a minimum of 6 feet or more from the base line. (In all divisions and categories).
- Sec. 76 STRIKE** is a legally pitched ball that lands entirely or partially, on any part of the home plate / strike mat.

Sec. 77 SUSPENDED GAME is a game called before being completed, which is to be completed at a later time, normally within the same day.

Sec. 78 TAG is the act of a fielder touching a base with any part of his body while holding the ball firmly and securely in his hand or glove or touching the baserunner with the ball, or with the glove holding the ball, while continuously holding the ball firmly and securely during and immediately following the tag. A player may be tagged between the "Commitment Line" and the "Scoring Line".

Sec. 79 THREE FOOT LINE is the designated running area at the latter half of the home to first base base path, in which a batter-baserunner must run, so as not to be called out for interfering with the first baseman's ability to receive a throw.

Sec. 80 THROW is the series of motions performed by a fielder, who subsequently releases the ball from his hand, with the ball being directed towards another fielder.

Sec. 81 TIEBREAKER is a method used to speed up the breaking of a tied game. The tiebreaker method starts in the top of the eighth (8th) inning and continues each inning thereafter. The offensive (at bat) team shall begin its half inning with one out and with the player whose name precedes the next legal batter in the batting order starting as a runner at second base. Regular substitution rules will apply to this runner (Tiebreaker Rule). Tiebreaker rule is recommended for all Provincial Championship games and will be used in all National Championship games.

Sec. 82 TIME or TIME OUT is the call made by an umpire when it is necessary to have the ball become dead and not in play.

Sec. 83 TRAPPED BALL is a fly ball that is not legally caught as outlined in Rule 3, Sec. 52. It is a fly ball which is held in the glove or in the hand, but is secured against the ground, and therefore is not a catch, but a ground ball.

Sec. 84 TRIPLE PLAY is any continuous play made by the defensive team in which three runners are put out, provided there is no error made in between the outs.

Sec. 85 TURN AT BAT starts when an offensive player first enters the batter's area and continues until he is put out or becomes a baserunner.

Sec. 86 UNLIMITED BATTING ORDER A team can use a batting order, which may include all active players on the official waiver/roster.

Sec. 87 WALK is when first base is awarded after four pitches have been called "balls" or an intentional walk has been given.

Sec. 88 WILD THROW is a thrown ball which remains in playable territory, but is thrown in such a manner that a fielder is not able to receive it properly. The ball is alive and playable.

RULE 4. - THE GAME

Sec. 1 THE CHOICE OF FIRST OR LAST BAT at the start of the game shall be decided by a toss of a coin.

Sec. 2 THE FITNESS OF THE GROUND for beginning a game shall be decided by the plate umpire. In tournament play, the umpire, in consultation with the Tournament Director, makes the decision. After a game has been started by the plate umpire, he shall be the sole judge as to whether or not the game shall continue.

Sec. 3 THE START OF THE GAME is the point in time when the teams have exchanged line-ups and completed the toss of the coin.

Sec. 4 A REGULATION GAME shall consist of seven innings, unless otherwise listed below:

- A. Seven full innings are not played if the home team scores the winning run in six innings or before the third out is made in their half of the seventh inning.
- B. The tie breaker rule comes into effect in the 8th inning of a tied game. If the person who is to start at 2nd base in that team's half of the inning is not available because they left the game due to injury, ejection or any other reason, and their spot in the batting order is the automatic out, then the person batting before them in the lineup will start out as the baserunner on 2nd base and there is one out. In Coed, if the automatic out is a female, then the runner at second will be the previous female in the batting order. If the automatic out is a male, then the runner at second will be the previous male in the batting order.
- C. A game called by the umpire, which cannot be resumed within 30 minutes, may be regulation if: five or more innings have been played or if the home team has scored the winning run during the uncompleted fifth inning; or, after four full innings, than the visiting team has scored in their five complete innings.
- D. A regulation game shall be declared if the score is TIED when the game is called, after five or more completed innings, or if the home team has equaled the score of the visiting team while batting during any uncompleted inning. (i.e. 4-1/2, 5-1/2, etc.)

NOTE: There can be no "ties" in National Championship games.

NOTE: The umpire is empowered to call a game at any time because of rain, lightning, darkness, panic or for any other case which puts the umpire, the players or patrons in peril.

- E. The mercy rule (12 runs) is in effect after five or more complete innings (or four and a half innings, if the home team has scored the 12 runs to mercy). The mercy rule applies after 4-1/2, 5, 5-1/2, 6, etc. The home team must have as many opportunities to bat (to tie or win the game) as the visiting team. In all mens and womens seniors divisions a mercy rule of 12 runs after 5 innings and 20 runs after 4 innings will apply to all games including finals. In any inning where the mercy rule applies, a team is allowed to score enough runs to bring them inside the run spread. (example: A team that trails by 18 runs in the 5th inning will be allowed to score up to 7 runs to get inside the 12 run rule.)
- F. In all SPN divisions, a 6 run rule will be used in each inning except when an inning is declared an "open inning" by the umpire.

Sec. 5 THE WINNER OF THE GAME shall be the team that scores the most runs in a regulation game.

- A. The total number of runs scored legally, when the game is called at the end of any completed inning after five, shall be the score.
- B. When the home team has scored the winning run during any uncompleted inning after four, or the visiting team has scored more runs than the home team after the end of any completed inning after five complete innings.

NOTE: If the last batter in a game hits a home run out of the playing field, or where a fence comes into play, the batter/baserunner and all runners on base are permitted to score in accordance with baserunning preceding rules, and the game ends when the batter/baserunner scores.

- C. If a game is to be called and the home team has not scored more runs, or does not score as many or more runs in their half of the uncompleted inning to tie or win the game, the game reverts to the last inning that was fully completed after five innings.
- D. Games that are not considered regulation, or regulation tie games, shall be replayed from the beginning. Original line-ups may be changed when the game is replayed.

Sec. 6 ONE RUN SHALL BE SCORED each time a baserunner legally touches first, second, third and the scoring line, before the third out of an inning, unless the third out is the result of a force out, or the batter-baserunner is out before reaching first base.

Sec. 7 A RUN SHALL NOT BE SCORED if the third out of an inning is the result of:

- A. The batter-baserunner being put out legally before touching first base.
- B. A baserunner forced out at any time.
- C. A baserunner being called out for leaving a base too soon on a pitched ball.
- D. A preceding baserunner being called out for failure to touch a base.

Sec. 8 A BASERUNNER SHALL NOT SCORE A RUN ahead of a baserunner preceding him in a team's batting order, if the preceding runner has not been put out.

EFFECT Sec. 8 A preceding runner appealed out for missing a base does not affect the following runners on first or second out. However, no preceding runner touching the scoring line may return to touch any missed base after the following runner has scored. If the fielding team appeals a preceding runner missing a base, and the appeal is upheld, the following runner's score is counted, unless the appealed out is the third out of the inning. If no appeal is made, then all runs scored are counted.

Sec. 9 A FORFEITED GAME shall be declared by the home plate umpire in favour of the team not at fault in the following cases:

- A. If a team fails to appear upon the field, or being on the field, refuses to begin the game for which it has been scheduled, at the time the game was assigned.
- B. If after a game has begun a team refuses to play or resume play as directed by the umpire.
- C. If a team uses tactics designed to delay or hasten the playing of a game.
- D. If an ejected player does not leave the ball park area within one minute of being ordered to do so.
- E. If for any reason a team does not have the designated number of players to begin or continue the game.
- F. If, after a warning by the umpire, any one of these rules is willfully violated.

EFFECT Sec. 9 A-F The score will be 7-0 in favour of the team not at fault.

Sec. 10 A SUSPENDED GAME can result in tournament or other play if the umpire stops play for any reason such as power failure of the lights, protested game in accordance with the rules, any act of God etc. that precludes immediate continuance of the game to the conclusion of the full seven innings, or as required. This means continuance of a game regardless of the time of the suspension of the game (ie. suspended for one hour, three hours, seven hours or the next day).

EFFECT Sec. 10 When a suspended game is resumed, it must be started at the point of interruption with the identical situations and line-ups as when the game was suspended.

RULE 5. - PLAYERS, SUBSTITUTES AND RE-ENTRY

Sec. 1 A TEAM must have a minimum of 10 players. Male teams shall consist of all male players, with the exception of coaches/managers and female teams shall consist of all female players with the exception of coaches/managers.

Sec. 2 PLAYERS DEFENSIVE POSITIONS

- 1) Pitcher 2) Catcher 3) First Baseman 4) Second Baseman 5) Third Baseman
6) Shortstop 7) Left Fielder 8) Left Centre 9) Right Centre 10) Right Fielder
11) Rover (Men's +65 and Women's Seniors)

A. Other than the pitcher and catcher, players in the field may be stationed anywhere they choose on fair ground as each pitch is delivered. No defensive player can stand closer than 50' in fair territory as each pitch is delivered.

(i) The pitcher, in delivering the ball must be in legal position within the pitching zone.

(ii) As each pitch is delivered, the catcher must be in the catcher's area.

Sec. 3

- A. **A TEAM** must have a minimum of 10 players to start, throughout and complete a game.
- B. In the Coed category where the Unlimited Batting Order is used, either one male and one female (or multiples thereof), may be used in accordance with Rule 13, Sec. 1.
- C. The batting order must remain constant and any 10 of the declared batting line-up may play defensively except in Men's +65 and Women's Seniors categories who can play with 11 defensive players. The players playing defensively may be changed at any time as long as there are no more than 10 defensive players, except in Men's +65 and Women's Seniors, who can use 11 defensive players.
- D. **All players eligible to play in a game must be listed on the line-up card submitted to the umpire. The line-up card must list the surname, given name and uniform number of the line-up players in the correct batting order. The surname, given name and uniform number of all substitutes must also be listed on the line-up card for each of the participating teams.**

NOTE: Failure to list a player on the line-up card submitted to the umpire results in the player being ineligible to play in the game.

Sec. 4 A TEAM must have the required number of players **IN UNIFORM** and in the dugout before a game can be started. When a line-up is submitted, all of the starting players must be available as stated above.

Sec. 5 NO DEFENSIVE PLAYER shall take a position in the batter's line of vision and with deliberate attempt, act unsportsmanlike in any manner in an effort to distract the batter. No defensive player can stand closer than 50' in fair territory as each pitch is delivered.

EFFECT Sec. 5 The umpire shall first warn the offender, and then eject any player from the game who repeats the offense.

Sec. 6 A PLAYER IS OFFICIALLY IN THE GAME when his name has been entered on the official score sheet. After the line-up card and official score sheet have been recognized, any substitutions must be made through the plate umpire, the change has to be acknowledged by the umpire in order to be classified as being officially in the game. A substitute may take the place of a player whose name is already entered in the team's batting order.

The following rules govern the substitution of players:

A. The Manager or team representative of the team making the substitution must immediately notify the plate umpire at the time a substitute enters the game.

EFFECT Sec. 6A Failure to notify the umpire is a violation and it is an illegal substitution and the player is immediately ejected from the game and said player is not allowed to participate in any capacity.

B. For purposes of the above rule (Rule 5 Sec. 6) a player shall be considered as being in the game:

- i) As a batter, when he takes his place in the batter's area;
- ii) As a fielder, when he takes the place of the fielder substituted for;
- iii) As a runner, when the substitute takes the base of the runner he is substituting for;
- iv) As a pitcher, when he takes his place within the pitching zone;
- v) As a courtesy runner, when he takes the base of the person he is running for.

C. Any player may be substituted for at any time.

Sec. 7 RE-ENTRY/SUBSTITUTIONS

A. The players in the starting line-up may be substituted for and may subsequently be re-entered once.

B. A starting player, if re-entered, must occupy the same position in the batting order.

C. The starting player and the substitute cannot be in the line-up at the same time.

EFFECT Sec. 6 and 7

A. If an **ILLEGAL SUBSTITUTION** (a player who is eligible to be in the game but is entered in the wrong position) is appealed on while the player is playing offensively, the following penalties will be enforced.

1. If an **ILLEGAL SUBSTITUTION** is appealed on while he is at bat, he is ejected. Baserunners will remain as they were because there would have been no advancement possible. The proper substitute/batter resumes the ball and strike count of the ejected player.
2. If an **ILLEGAL SUBSTITUTION** is appealed on after the batter has completed his turn at bat and before the next pitch, the illegal player is ejected and any advance of baserunners as a result of a walk or base hit by the illegal batter, is nullified. The proper substitute/batter will then bat. If an out was made on the play, the "out" stands.
3. If an **ILLEGAL SUBSTITUTION** is appealed on after the batter has completed his turn at bat and after the next pitch, the illegal player is ejected and any advance by baserunners while the illegal batter was at bat, is legal. The next batter is the one following the illegal substitute and, if applicable, other batters lose their turn at bat.

B. If an **ILLEGAL RE-ENTRY** (a player who is not eligible to be in the game) is appealed on while the player is playing offensively, the following penalties will be enforced:

1. If an **ILLEGAL RE-ENTRY** is appealed on while he is at bat, he is out and ejected. Baserunners will remain as they were because there would have been no advancement possible.
2. If an **ILLEGAL RE-ENTRY** is appealed on after the batter has completed his turn at bat and before the next pitch, the illegal player is out and ejected and any advance as a result of a walk or base hit by the illegal batter is nullified.
3. If an **ILLEGAL RE-ENTRY** is appealed on after the batter has completed his turn at bat and after the next pitch, the illegal player is out and ejected and any advance by baserunners while the illegal batter was at bat, is legal.

EFFECT Sec. 6 and 7 B 1-3 The penalty for an offensive **ILLEGAL RE-ENTRY** is that the illegal player is out and ejected plus the manager/coach is ejected.

EFFECT Sec. 6 and 7

C. If an illegal substitution or illegal re-entry is appealed on while the player is playing defensively, the following penalties will be enforced:

1. If an illegal substitution or illegal re-entry is appealed on after he makes a play and before the next pitch, the offensive team has the option of taking the result of the play or of having the last batter go back to bat assuming the balls and strikes count the batter had prior to the discovery of the illegal player and having all baserunners returning to the last base they held prior to the play. The illegal substitute is ejected.
2. If the illegal substitution or illegal re-entry player is appealed on after a pitch to the next batter, the illegal substitute is ejected and all play stands.

EFFECT Sec. 7 C 1 & 2

1. The penalty for an illegal defensive re-entry is that the illegal player and the manager/coach (the name that appears on the line-up card) are both ejected from the game.
2. The penalty for an illegal defensive substitution is that the illegal substitute is ejected from the game.

NOTE: Players ejected for illegal re-entry or illegal substitution may not remain on the bench.

Sec. 8 BLOOD RULE: Injured or Bleeding player

A. Any player who is injured or is bleeding from an injury and is assumed to be able to continue to play in the game, will be given a reasonable amount of time to tend to his injury or the bleeding. A reasonable amount of time will be determined by the umpire.

B. A player who is bleeding must be immediately removed from the playing field to have the bleeding controlled, cleaned up and the wound completely covered. If there is blood on any of the player's clothing, then the clothing must be changed before a player is allowed to participate in the game again.

EFFECT Sec. 8 If the player cannot return to the playing field in a reasonable amount of time, then a legal substitution or re-entry must take place when advised by the umpire that time is up. If this is not possible, the game will be forfeited if the team has less than 10 players.

NOTE: The ruling regarding a bleeding injury also applies to umpires, coaches, managers, etc. in that continued participation in the game will not be allowed if the bleeding is not controlled, covered and the applicable clothing changed.

Sec. 9 THERE SHALL NOT be more than two coaches for the offensive team to give words of assistance and directions to the members of their own team. One coach may be stationed in each coaching box at first and third bases. They must remain in the boxes.

Sec. 10 MANAGER, COACHES, PLAYERS, SUBSTITUTES, TRAINERS, BAT BOYS or other team members or occupants of the bench shall not, from any place including the coaches' box:

- A. Incite, or try to incite by word, sign or demonstration, either opponents and/or spectators.
- B. Use language which will in any manner refer to or reflect upon opposing players, teammates, umpires or spectators.
- C. Commit any act that could be considered unsportsmanlike conduct.
- D. Approach umpire with a rulebook visibly in hand, in an attempt to question, argue, or dispute an umpire's decision.

EFFECT Sec. 10 A-C For a first offense the violator should be warned that to repeat the offense will cause prompt ejection from the game. All flagrant offenses (including a first offense) will be cause for the offender to be immediately removed from the game and playing area. An ejected player must leave the park immediately.

EFFECT Sec. 10 D Immediate ejection.

RULE 6. - PITCHING

Sec. 1 AT THE BEGINNING of each half of the first inning, five practice pitches will be allowed and then 1 pitch at the beginning of each subsequent inning, or when a pitcher relieves another pitcher, one minute may be used to deliver not more than three practice pitches to the catcher, or some other teammate.

Sec. 2 LEGAL POSITIONS OF THE PITCHER'S FEET:

A. Preliminary to pitching, the pitcher shall take a position with his pivot foot firmly on the ground within the confines of the pitching zone. The pivot foot must remain in constant contact within the pitching zone, until the release of the ball.

B. The other foot (free foot) has no restrictions on position and may be placed on, in front of, to the rear of, or to the side of the pitching zone. After taking this initial position, the pitcher may only take one step with the free foot in a direction of his choice, provided that it is taken prior to, simultaneously with, and during the actions of delivering the pitched ball.

C. After the release of the pitch, which action may include a step forward towards the batter, the pitcher may not continue to move forward, other than the normal forward momentum resultant from the pitch to the batter.

EFFECT Sec. 2 C If the pitcher continues to move forward in an attempt to distract the batter, on the first offence, the pitcher shall be warned. On the second offence, the pitcher shall be ejected from the game and the batter awarded first base.

Sec. 3 PITCHER'S LEGAL MOTIONS ALLOWED IN ACTUAL DELIVERY OF A PITCH:

A. After assuming the pitching position, the pitcher must hold the ball in front of his body (and be motionless for at least one second) in either one or both hands, before starting the delivery motions. The pitcher must face the home plate / strike mat when starting delivery of the pitch.

B. The pitcher may hold or grip the ball in any manner before delivery.

C. The pitcher may release the pitched ball in any manner when delivering the pitch; this includes any and all types of delivery. After the pitcher has come to his complete stop, he has 5 seconds in which he may use any wind-up or arm motion desired, either in front of his body, above his head, or behind his back including stops and pauses, before he must release the ball.

D. Only a definite underhand motion is permitted in the delivery of the pitch.

E. The pitcher may release the pitched ball with the hand above the hip in order to obtain the necessary arc.

F. Once a pitcher starts his pitching motion, the batter may not request time out.

Sec. 4 LEGALLY DELIVERED PITCHES:

A. The pitch shall be delivered at a moderate speed. The umpire shall warn the pitcher who delivers a pitch with excessive speed.

B. The pitched ball must have a perceptible arc of at least 6 feet from the ground before it passes any part of home plate / strike mat and shall not reach a height of more than 12 feet at its highest point from the ground.

C. The catcher must be within the catcher's area until the pitched ball is batted, reaches or passes the home plate / strike mat.

D. The catcher shall return the ball directly to the pitcher after each pitch except after a strike out, or an out made by the catcher. The pitcher has 20 seconds to release the next pitch.

EFFECT Sec. 4 A-D Failure to comply will constitute an illegally pitched ball and a ball will be awarded to the batter.

EFFECT Sec. 4 A If the pitcher continues to pitch with excessive speed, he shall be removed from the pitching position for the remainder of the game.

E. The catcher shall not place his glove on the ground in the area inside the batter's area before the ball has reached or passed the home plate / strike mat or has been batted.

EFFECT Sec. 4E A warning will be issued on the first offense. Any additional infractions will be called an illegal pitch and a ball will be awarded to the batter.

Sec. 5 NO PITCH shall be declared immediately when:

- A. The pitcher pitches during a dead ball interval.
- B. A baserunner is called out for leaving a base too soon.
- C. A pitcher attempts to "quick pitch" a batter.
- D. The pitcher delivers the ball from the catching glove.

Sec. 6 ILLEGALLY PITCHED BALLS INCLUDE:

- A. Any pitched ball that does not conform to all the requirements of a legally delivered pitched ball.
- B. All pitches made by the pitcher, when not conforming to pitching restrictions.
- C. Delivering a pitch from other than the pitching zone and pitcher's position.
- D. The pitcher failing to face the home plate / strike mat on delivery of the pitch.
- E. When the pitcher moves towards the batter after releasing the pitch.

EFFECT Sec. 6 A-E In each case an illegally pitched ball shall be called immediately when it occurs and a ball will be awarded to the batter. The umpire, base or plate, will call the illegal pitch loud enough for the batter to hear. However, if the batter swings at an illegally pitched ball, the pitch will immediately become legal. The ball is alive and in play if hit by the batter.

Sec. 7 ILLEGAL PITCHING ACTIONS INCLUDE:

- A. The pitcher, after assuming the pitching position, holding the ball longer than 5 seconds.
- B. Throwing the ball by the pitcher to any fielder, unless performing preliminary warm-up pitches or making an effort to complete an appeal play, or while the ball is dead.
- C. The pitcher failing to take a position within the pitching zone, in an attempt to delay the game.

EFFECT Sec. 8 A-C The umpire shall immediately call "TIME" thus causing the play to be dead and award a ball to the batter.

Sec. 8 APPEALING WHILE BALL IS ALIVE

Any fielder may appeal a runner once per base; the ball is alive and all runners may advance with liability of being put out.

NOTE: On appeal plays, the appeal must be made before the next pitch (legal or illegal) or before all defensive players have left fair territory.

Sec. 9 APPEALING AFTER BALL IS DEAD/DEAD BALL APPEAL

Once the ball has been returned to the infield and "TIME" has been called by the umpire, or the ball becomes dead, any infielder, including the pitcher or catcher, with or without possession of the ball, may make a verbal appeal on a runner missing a base or leaving a base prior to a ball being caught. The appropriate umpire must acknowledge the appeal and then make a decision on the play. Baserunners may not leave their bases during this appeal process, as the ball remains dead until the umpire calls "PLAY BALL".

Sec. 10 DEFENSIVE CHARGED CONFERENCE

There may only be one charged conference between the manager, or other team representative from the dugout area with each and every pitcher in a game. The second charged conference will result in the removal of the pitcher from the pitching position for the remainder of the game, but he can play any other position.

Sec. 11 QUICK PITCH

A quick pitch is a pitch made by a pitcher with the intent of catching the batter off guard or off balance. This could be when the batter first takes his position or is off balance from the previous pitch.

EFFECT Sec. 11 The ball is dead and "No Pitch" shall be called by the umpire.

RULE 7. - BATTING

Sec. 1 UNLIMITED BATTING ORDER A team may bat as many players as they wish – maximum of 10 players on the field at any one time. If a player is removed from the game due to an injury, ejection, etc., the automatic out will be recorded each time that player is due to bat, if there is no substitute for them. A team must finish the game with at least 10 players in the line-up. Coed line-up must always contain an even number of males/females, except as allowed under Rule 13 Sec. 1. In Coed, only the player who left the game due to an injury, ejection etc. is removed from the game.

Sec. 2 THE BATTING ORDER of each team must be listed and delivered to the **OFFICIAL SCOREKEEPER** by the **MANAGER**, or team representative. **SHOULD** an Official Scorekeeper not be assigned to the game, the **BATTING ORDER** must be delivered to the Plate Umpire prior to the starting time of the game. After each team has submitted its own batting order, both line-ups shall be made available to both teams, for their inspection and knowledge.

EFFECT Sec. 2 Each manager must have submitted his own team's line-up before he can have access to the line-up of his opponents. The umpire may forfeit the game if there is unwarranted delay in providing a line-up.

- A. The batting order submitted must be followed throughout the game, unless a substitute replaces a player. When this occurs, the substitute must take the turn at bat of the player he replaces in the original batting order.
- B. Each player of the team at bat shall become the batter and enter the batter's area in the order in which his name appears on the score sheet/line-up card.
- C. The first batter in each succeeding inning shall be the batter whose name follows that of the player who last completed a turn at bat in the preceding inning.
- D. A batter completes a turn at bat when he has either been put out or has become a baserunner.
- E. When the third out of an inning is made before the batter has completed his turn at bat, the same batter will be the first batter in the next inning and all previous called balls and strikes will be cancelled.

EFFECT Sec. 2 A-C Batting out of order is an appeal play situation.

1. If an incorrect batter is discovered before he completes his turn at bat, the correct batter may take his proper place, assuming any accumulated balls and strikes.

NOTE: In this situation, an appeal may be made by the offensive or defensive team.

2. If the mistake is discovered after the incorrect batter has completed his turn at bat, and before a pitch has been made to a succeeding batter, the batter who should have batted is called out. All baserunners, if they have advanced, must return to the base occupied at the time the incorrect batter took a position in the batter's area. The next batter is the player whose name follows that of the batter called out for failure to bat. If the appealed out was the third out then the next batter in the next inning is still the batter whose name follows that of the batter called out for failure to bat. An illegal batter is removed from base.

NOTE: In situation 2, only the defensive team can appeal.

3. If the mistake is not discovered until after a pitch is made to a next batter, the turn at bat of the incorrect batter is then legal. All bases advanced or runs scored are counted, and the next batter shall be the one whose name follows that of the incorrect batter who has just finished a time at bat. No one is called out for failure to bat, and players missing their turn at bat have lost that turn and do not bat again until reached in the regular batting rotation.

NOTE: For purposes of interpretation, an intentional walk to a next batter or illegal pitcher's action, shall be considered the same as a pitch delivered to a batter.

4. A baserunner who has batted out of order will not be removed from the base he is occupying to bat in his proper place. He misses his turn at bat with no penalty. The next legal batter will be the one who follows him in the batting order.

Sec. 3 THE BATTER IS OUT IF:

- A. He illegally hits the ball, eg. when his foot is in contact with the home plate / strike mat. He places both of his feet on the ground completely outside the approved batter's area (see Rule 3, Sec 11). He makes contact with the ball with one foot on the ground, completely within the 22 inch area in front

of the leading edge of the home plate / strike mat or completely within the 22 inch area at the back edge of the home plate / strike mat.

- B. He enters the batter's area with an illegal / non-approved bat.
- C. He deliberately bunts or swings the bat downward and chops the ball down to the ground.
- D. He hits a foul ball or foul tip after two strikes.
- E. He steps across the home plate / strike mat with the pitcher in the pitching position.
- F. He intentionally interferes with the catcher attempting a play.
- G. Any member of his team (excluding baserunners) interferes with a fielder attempting to make a play on a foul fly ball.
- H. He hits a fair fly ball or line drive that a fielder or infielder intentionally drops, with a runner on first, first and second, first, second and third, or first and third, with less than two outs.

NOTE: A trapped ball that hits the ground is never ruled intentionally dropped.

- I. He takes longer than 20 seconds to enter the batter's area when it becomes his turn to bat, or 10 seconds to re-enter the area after a called ball, strike or foul ball.
- J. A preceding runner, who is not yet out, intentionally interferes with a fielder who is attempting to catch a thrown ball or to throw a ball in an attempt to complete a play. The runner shall also be called out.
- K. He hits a fair ball with his bat a second time in fair territory.

NOTE: If the batter drops the bat and the ball rolls to the bat, in fair territory, the batter is not out and the ball is alive and in play. However, if the bat rolls towards the ball and subsequently hits it in fair territory, the batter is out, the ball is dead.

- L. There is spectator interference with any batted ball, that clearly prevents a fielder from catching a fly ball within the defined playing area.

EFFECT Sec. 3 B The batter is out. The batter and the coach are both ejected from the game.

EFFECT Sec. 3 A, C, D, E, F, G, H, I, J, K, L The ball is dead, the batter is out and the runners may not advance.

- M. He enters the batter's area with an altered bat.

EFFECT Sec. 3 M The ball is dead, the batter is out and is ejected from the game.

- N. He hits a fly ball, whether fair or foul, or a foul tip, that is legally caught.

EFFECT Sec. 3 N The batter is out, the ball remains alive and baserunners are in jeopardy.

- O. He has three strikes.

- P. He hits an infield fly, with runners on first and second, or on first, second and third bases with less than two out.

EFFECT Sec. 3 P The ball remains alive and in play, with runners in jeopardy.

1. If a declared infield fly falls to the ground untouched and bounces foul before passing first or third base, it is a foul ball.
2. If a fly ball falls to the ground untouched outside the foul lines and then bounces fair, before reaching first or third bases, it is an infield fly.

- Q. He carries the bat to first base. If a batter, carrying a bat, legally reaches or touches first base, the batter is out.

- R. The batter directs or utters profanities at an umpire, another player or participant, and/or utters profanities whereby the spectator can hear it; **OR** if he is the first batter up after a member of his team when playing defensively, was guilty of an infraction under the profanity rule, after both teams have received a mutual warning, for the first occurrence of profanity by either team.

NOTE: 1. The first occurrence of profanity by any coach and/or player of either team will result in a warning to both teams.

2. A second occurrence would result in the offending player being called out if he is a batter, batter-baserunner, or a baserunner, **OR** the next batter on the offending team would be called out if the infraction was by a batter, batter-baserunner, baserunner,

coach, a defensive player or by a non-participating player (player on the bench).

EFFECT Sec. 3 R This is a delayed dead ball call. If the batter is put out as a result of the play, the out will be enforced with the following batter in the batting order. If the batter reaches base safely then he alone will be called out for the use of profanity when the umpire calls "Time".

5. He hits an over the fence home run that is in excess of the number allowed in that category of play.

Sec. 4 A BATTER-BASERUNNER OR BASERUNNER IS NOT OUT IF a fielder making a play uses an illegal glove.

EFFECT: Sec. 4 The manager of the offensive team has the option of taking the result of the play or having the batter go back up to bat and assume the count he had prior to the hit.

Sec. 5 ON DECK BATTER:

- A. The on deck batter is the person whose name is next on the line-up card after the batter.
- B. The on deck batter must position himself within the lines of the on deck circle nearest his team's bench.
- C. The on deck batter may leave the circle when he is to become the batter or when he is going to direct a baserunner advancing towards the scoring line.
- D. If the on deck batter interferes with a defensive player making a play on the ball, the runner closest to the scoring line at the home plate / strike mat at the time of the interference will be called out.

Sec. 6 A STRIKE IS CALLED BY THE UMPIRE:

- A. For each fairly delivered pitched ball by the pitcher, that lands entirely or partially, on any part of the home plate / strike mat, before touching the ground.
- B. For each pitch struck at and missed by the batter.
- C. For each batted ball striking the batter, while he is in the batter's area.
- D. For each foul ball not caught on the fly.
- E. For leaving the batter's area after the pitcher starts his pitching motion.

EFFECT Sec. 6 The ball is dead after any strike.

Sec. 7 A BALL IS CALLED BY THE UMPIRE on each pitch not swung at by the batter, if:

- A. The pitched ball does not land completely or partially on any part of the home plate / strike mat.
- B. The ball strikes the ground before reaching or landing on any part of the home plate / strike mat.

NOTE: The ball is dead when the legal pitch has contacted the ground. A batter may not hit a ball that hits the ground prior to reaching the home plate / strike mat.

- C. An illegally pitched ball is delivered but not struck at.
- D. There is an illegal pitcher action.
- E. When the catcher fails to return the ball directly to the pitcher except after a strike-out or put out by the catcher.

Sec. 8 A FAIR BATTED BALL is a legally batted ball which is immediately in play.

It is a legally batted ball which:

- A. Settles or is first touched on fair ground between the home plate / strike mat and first base or between the home plate / strike mat and third base.
- B. Bounds past first or third base while on or over fair territory.
- C. Touches first, second or third base.
- D. Touches the person or clothing of an umpire or player while on or over fair territory.
- E. Falls to the ground in foul territory, then rolls or bounces into fair territory before passing first or third bases, and without having touched some object other than the ground.

F. First touches the ground in fair territory, then rolls into foul territory and then again rolls into fair territory, provided the ball did not touch anything while on or over foul territory, other than the ground.

Sec. 9 FOUL BALL is a legally batted ball which does not conform to the provisions or rules that would cause it to be a fair ball. It is a ball which:

- A. Settles or is first touched on foul ground between the home plate / strike mat and first base or between the home plate / strike mat and third base.
- B. Goes past first or third base while on or over foul ground.
- C. First touches the ground in foul territory beyond first or third base.
- D. While on or over foul territory touches the person or clothing of an umpire, player or is blocked.

EFFECT Sec. 9 A-D A strike is called on the batter unless he already has two strikes then a strike is called and the batter is out. Baserunners must return to their bases unless it is a caught fly ball, then the ball is alive and all baserunners are in jeopardy.

NOTE: A fair or foul ball shall be judged according to the position of the ball, relative to the FOUL LINES including the FOUL POLE, and not whether the fielder is on or over either fair or foul territory, at the time the ball is first touched. (Foul Lines and Foul Poles are in fair territory). When a batted ball passes out of the field over a fence, the umpire shall declare it fair or foul, according to the position of the ball, as it leaves the playing field. When a batted ball hits any object including a fielder and is ruled a fair ball under the above rules, it is always treated as a fair ball regardless of what happens to the ball, or where it may subsequently settle or land. A fly ball landing beyond first or third base is judged at point of the first contact.

Sec. 10 FOUL TIP is any tipped ball that is caught by the catcher.

EFFECT Sec. 10 It is a foul tip only if it is legally caught and the batter is out. The ball remains alive and all baserunners are in jeopardy.

Sec. 11 HOME RUN RULE will apply.

A. Any undeflected ball hit over the fence will be considered as a home run for the designated allowances for home runs for all divisions and categories.

EFFECT Sec. 11A Where an over the fence home run is hit that is in excess of the number allowed, the batter will be called out.

B. When a fair batted fly ball deflects off a defensive player over the home run fence, the batter-baserunner will be awarded four (4) bases. This will not be considered the same as an over the fence home run.

Sec. 12 OFFENSIVE CHARGED CONFERENCE: There shall be only two charged conferences allowed per inning between the Manager or other team representative and the batter or baserunner. Umpires shall not permit any in excess of two in an inning.

EFFECT Sec. 12 A manager, coach or other team representative who insists on a third conference is to be ejected from the game.

RULE 8. - BASERUNNING

Sec. 1 A BASERUNNER WHILE ADVANCING OR RETURNING, MUST TOUCH EACH BASE IN LEGAL ORDER: (i.e. FROM FIRST BASE, SECOND BASE, THIRD BASE TO THE SCORING LINE)

A. A baserunner may only acquire the right to an advanced base by touching it before having been put out, and shall be entitled to hold such base until he touches the next base legally, or is forced to leave the base when the batter becomes a baserunner.

B. When the ball is alive and a baserunner must return to touch a base, he must touch all bases in reverse order.

EFFECT Sec. 1 B The baserunner is in jeopardy and could be put out.

Sec. 2 THE BATTER BECOMES A BATTER-BASERUNNER AS SOON AS HE HITS THE BALL:

A. If the fair batted ball hits the umpire or baserunner while off the base, after passing a fielder other than the pitcher, or touches any fielder including the pitcher, it remains in play, with all runners being in jeopardy.

B. When a fair ball strikes the person or clothing of an umpire while on foul ground.

EFFECT Sec. 2 A-B The batter-baserunner is immediately in jeopardy.

Sec. 3 THE BATTER IS AWARDED FIRST BASE:

A. When four balls are called by the umpire.

B. When the pitcher tells the umpire to intentionally walk a batter, once the batter takes his position in the batter's area.

EFFECT Sec. 3 A-B The batter is awarded first base only except in Coed ball, if a male batter is walked intentionally or otherwise he will be awarded two bases. The ball is dead. Baserunners advance only if forced to do so.

C. If a fair batted ball strikes a baserunner while he is off his base, and before passing a fielder other than the pitcher, the ball is immediately dead and the batter is entitled to first base without liability to be put out.

D. If a fair batted ball strikes the umpire in fair territory, before passing a fielder, other than the pitcher, the ball is immediately dead and the batter is entitled to first base without liability to be put out.

E. If the catcher or other fielder obstructs him or prevents him from striking at a pitched ball.

EFFECT Sec. 3 E It is a delayed dead ball call and if called, the offensive manager has the option to accept the obstruction or take the result of the play **EXCEPT** that if the batter succeeds in hitting the pitch and reaches first base safely, and all preceding runners have advanced at least one base safely, the obstruction will be nullified. If the obstruction is nullified, the ball remains alive and in play and there is no option play.

Sec. 4 BATTER-BASERUNNERS ARE OUT under the following circumstances:

A. When he is hit by his own batted ball in fair territory, after leaving the batter's area.

B. When he drops the bat in fair territory and it makes contact with a fair ball, by moving into the ball.

C. When a fly ball is legally caught, providing no part of the fielder's body is touching in "out of play territory" at the time of the catch.

D. When, after a fair ball is hit, he is touched with the ball by a fielder prior to first base, while off the base.

E. When, after a fair ball is hit, a fielder holds the ball on first base before the batter-baserunner touches or passes the base.

F. When, after reaching first base safely, he overruns or overslides that base, and then makes an attempt to start to second base and is tagged before returning to first base.

G. When he runs out of the three foot line and interferes with a fielder taking a throw, or making a play at first base.

EFFECT Sec. 4 G He is out and if the interference is deemed to be intentional the most advanced baserunner is also out.

H. If between the home plate / strike mat and first base, he moves back toward the home plate / strike mat to avoid or delay being tagged.

EFFECT Sec. 4 H The ball is dead and all baserunners must return to the last base touched at the time of the interference.

I. If he interferes with a play at the scoring line at the home plate / strike mat in an attempt to prevent an obvious out.

EFFECT Sec. 4 I The baserunner is also out.

J. If he physically and/or verbally interferes with a fielder attempting to field a batted ball or intentionally interferes physically and/or verbally with a thrown ball.

EFFECT Sec. 4 J If this interference is an obvious attempt to prevent a double play, the baserunner closest to the scoring line at the home plate / strike mat shall also be called out.

K. If he carries the bat and legally reaches or touches first base with the bat still in his hand.

L. When a play is being made at first base, he touches only the white portion of the double base.

M. If he is called on the infraction of directing or uttering profanities at an umpire, another player or participant and/or utters profanities whereby the spectators can hear it after a warning has been given to both teams for the first occurrence of profanity from either team.

N. If he physically passes a preceding baserunner before that baserunner has been put out.

EFFECT Sec. 4 K-N The batter is out and the ball is alive, unless the act interferes with the play, then the batter is out and the ball is dead and all baserunners must return to the last base touched at the time of the interference.

Sec. 5 A BASERUNNER IS OUT under the following circumstances:

A. If he fails to keep contact with the base to which he is entitled, until a pitched ball has reached or passed or bounced in front of the home plate / strike mat or is batted.

EFFECT Sec. 5 A No pitch is declared, the ball is dead and the runner is out.

B. If he physically and/or verbally interferes with a fielder attempting to field a batted ball or intentionally interferes, physically and/or verbally, with a fielder catching a ball, throwing a ball, or with a thrown ball.

EFFECT Sec. 5 B The ball is dead, the baserunner is out and if the interference is deemed to be intentional, the next succeeding baserunner is also out.

C. If he is struck by a fair batted ball on fair ground **WHILE OFF HIS BASE** and before it passes a fielder, excluding the pitcher, unless of course, in the umpire's judgement, no infielder is in position to field the ball.

D. If he runs bases in reverse order, other than what is allowed under what constitutes legal baserunning.

E. If he intentionally kicks a live ball, or intentionally interferes with a ball in play, whether or not the baserunner is in contact with his base, and an infielder **HAS HAD** an opportunity to play the ball.

EFFECT Sec. 5 C-E The ball is dead and the baserunner is out.

F. When a coach physically holds or pushes a baserunner to assist him to return or to leave a base.

EFFECT Sec. 5 F The baserunner is out, the ball is alive and all other baserunners continue to be in jeopardy.

G. If he intentionally kicks a live ball, or intentionally interferes with a ball in play, whether or not the baserunner is in contact with his base, and an infielder **HAS NOT HAD** an opportunity to play the ball.

H. If he has been put out and continues to run the bases, simulating a live baserunner, and thereby draws a throw to retire him a second time.

I. When one or more members of the team at bat, stands, or collects at, or around, a base toward which a baserunner is advancing, thereby confusing the fielders.

J. When a coach intentionally interferes with a live batted or thrown ball.

K. When a coach runs in the direction of the scoring line at the home plate / strike mat or any other base, on or near a baseline, while the fielder is attempting to make a play on a batted ball, or on a thrown ball, and thereby drawing a throw in his direction.

L. If he is attempting to score and the next batter or other team members interfere with the attempted play.

EFFECT Sec. 5 G-L Interference is called, the ball is dead and the **MOST ADVANCED RUNNER IS ALSO CALLED OUT.**

M. When, while the ball is in play, he is off the base and is legally touched with the ball.

N. When, on a force out, a fielder tags him with the ball or holds the ball on the base to which the baserunner is forced to advance, before the baserunner can reach that base.

O. When running toward any base, he runs more than three feet outside his established base path to avoid being tagged with the ball in the hands of a fielder.

P. If he physically passes a preceding baserunner before that baserunner has been put out.

Q. When he positions himself behind and not in contact with the base to get a running start on any fly ball.

EFFECT Sec. 5 M-Q The ball remains alive and in play and all other baserunners are in jeopardy.

R. When he positions himself behind and not in contact with the base to get a running start when the pitch has been released but has not yet reached or crossed the home plate / strike mat or been hit.

EFFECT Sec. 5 R This is a lead off, the ball is dead, the baserunner is out and all other baserunners must return to the last base legally held at the time of the pitch. **"No Pitch"** will be called by the plate umpire.

S. If he fails to return to touch the base to which he is entitled when play is resumed after any suspension of play, if a fielder legally holds the ball on that base.

T. If he leaves his base to advance to the next base before a fly ball has been touched or touches some object, provided that if the fly ball is caught and returned to a fielder and legally held on the base left or if a fielder touches the runner with the ball, before the runner returns to retouch his original base.

U. When he fails to touch an intervening base or bases (including awarded bases) in regular or reverse order, while the ball is in play, and the ball is held legally on the missed base, or the runner is legally touched with the ball, while off the base.

EFFECT Sec. 5 S-U These are appeal plays and the defensive team loses its right to make an appeal on any of these situations, if the appeal is not made known before the next legal or illegal pitch, intentional walk, or illegal pitcher action or before all fielders have left fair territory.

V. When running to the scoring line, he doesn't cross the scoring line and a fielder holds the ball in his hand while touching the home plate / strike mat and appeals to the umpire. Also runners attempting to score by touching the scoring line are out if they touch the home plate / strike mat or cross over the home plate / strike mat in fair territory, whether a play is made or not.

1. Unless two are out, the status of a following runner is not affected by a preceding runner's violation or failure to comply.

2. If, on an appeal, the preceding runner is the **THIRD OUT**, no following runner shall be allowed to score.

3. If an appealed out is the **THIRD OUT**, and is the result of a force out, neither preceding nor following runners shall score.

4. If the appealed out is the **THIRD OUT**, and is the result of the batter-baserunner not touching first base, preceding runners shall not score.

5. On any appealed play not a force out, all runners in advance of a baserunner being appealed out, who touch the scoring line legally before completion of the **THIRD APPEALED OUT** shall be counted. Succeeding runners cannot score.

W. When a defensive player clearly has the ball and is waiting for the runner and the runner deliberately with great force crashes into the defensive player.

EFFECT Sec. 5 W The offender is out and shall be ejected, the ball is dead and all other baserunners must return to the last base touched at the time of the infraction.

X. If he is called on the infraction of directing or uttering profanities at an umpire, another player or participant and/or utters profanities whereby the spectators can hear it, after a warning has been given to both teams for the first occurrence of profanity from either team.

EFFECT Sec. 5 X The ball remains alive and all other baserunners are in jeopardy.

Sec. 6 BASERUNNERS ARE ENTITLED TO ADVANCE WITH LIABILITY TO BE OUT:

A. When any live ball continues to be in play.

EFFECT Sec. 6 A 1. The umpire shall call **"TIME"** when the baserunners cease to try to advance and a fielder has control of the ball in the infield.
2. If a ball is no longer alive and in play as determined by the stoppage of play and the umpire having called **"TIME"**, baserunners must return to the last base touched and entitled to when all play stopped.

B. When during a live ball play, following a batted ball, and the ball is a wild throw in either fair or foul territory and does not become a blocked ball.

C. When any legally caught fly ball, is first touched by a fielder.

D. When a live thrown ball strikes the person of an umpire, coach or baserunner.

E. When a fair batted ball, or live thrown ball accidentally strikes a coach.

F. When another baserunner physically passes a preceding baserunner.

G. When a preceding baserunner fails to touch a base as required.

EFFECT Sec. 6 B-G The ball remains alive, with all baserunners continuing to be in jeopardy.

EFFECT Sec. 6 F The baserunner who passes the preceding runner is out.

H. When a defensive player deliberately or otherwise contacts, catches or stops a batted or thrown ball, using any object, including his cap, glove or any part of his uniform or equipment while it is detached from its proper place on the fielder's person.

EFFECT Sec. 6 H It is delayed dead ball call and

1. On a fair batted ball, or on a ball that may become fair, all baserunners are entitled to advance 3 bases from the time of the pitch.

2. On a thrown ball all baserunners are entitled to advance 2 bases from the time of the throw.

3. In both situations, the baserunners may advance further than the bases to which they are awarded but they will be in jeopardy.

NOTE: If, in the opinion of the umpire, a fair batted ball would have cleared the outfield fence, had it not been interfered with, the batter-baserunner will be awarded four (4) bases.

I. If a baserunner dislodges a base from its proper position neither he nor any succeeding baserunner in the same series of plays, are obligated to run to a base that is unreasonably out of its proper place.

EFFECT Sec. 6 I The ball is alive and baserunners may advance with liability to be put out.

J. When a fair batted ball has been touched by a fielder, including the pitcher.

EFFECT Sec. 6 J The ball remains alive with all baserunners continuing to be in jeopardy.

Sec. 7 BASERUNNERS ARE ENTITLED TO ADVANCE WITHOUT LIABILITY TO BE PUT OUT:

A. When a fair fly ball goes over the home run fence or into the stands in the established outfield "out of play territory" without touching the ground or a defensive player, the batter shall be entitled to a home run.

1. A fair ball that clears the fence before touching anything or anyone, and which is not caught is a home run. This includes any ball that hits the top of the fence and goes over it.

2. When a fair batted fly ball deflects off a defensive player over the home run fence, the batter-baserunner will be awarded four (4) bases.

3. When a batted ball, either fair or foul is legally caught on the fly, and the fielder has not yet touched any area outside the lines of the established playing area. The batter is out, but if the fielder's momentum causes him to touch, or to go completely into the "out of play area", the ball will be declared dead and all baserunners will be awarded one base from the last base legally touched at the time of the catch. If the ball is intentionally carried into "out of play territory" the award will be a minimum of two bases.

B. When a fair batted ball bounds or rolls into the stands, over, under or through a fence or other boundary of the playing field whether or not the batted ball is first touched by a fielder.

EFFECT Sec. 7 B The ball is dead, baserunners are awarded two bases from the last base held at the time of the pitch.

C. When while in contact with the base, the baserunner is hit with a fair batted ball and it is deemed to be alive and it subsequently becomes blocked.

EFFECT Sec. 7 C The ball is dead and the batter and all baserunners will be awarded one base from the last base legally touched at the time the ball is blocked.

D. When forced to advance because of the batter being awarded first base.

E. If he is obstructed by a fielder between bases, or as he rounds a base, unless the fielder is trying to field a batted ball, thrown ball, or has the ball in his possession ready to tag the baserunner.

EFFECT Sec. 7 E The obstructed baserunner shall be awarded at least one base beyond the base he had last legally touched before the obstruction. The umpire shall also award the obstructed baserunner all other bases he believes the baserunner would have made, had no obstruction occurred. Any preceding baserunners forced to advance to the next base due to the award, are not in jeopardy. If the baserunner continues beyond the base he would have been awarded for the obstruction, he is in jeopardy. The ball remains alive with all other baserunners also in jeopardy.

F. If a baserunner is obstructed during a rundown, he will be awarded the base he was running toward at the time of the obstruction.

EFFECT Sec. 7 F The runner is to be awarded the base he was **RUNNING TOWARDS** at the time of the obstruction. The obstruction is delayed dead ball call and will be enforced at the completion of the play, or , if applicable, nullified while the play is still in progress.

G. If a batted ball, when played, is thrown wildly and goes into foul territory and is subsequently blocked.

EFFECT Sec. 7 G When a blocked ball occurs on a thrown live ball, the ball is immediately dead. Each and every baserunner is awarded two bases from the last base occupied at the time of the throw. The lead runner governs the award.

H. When an accident or incident occurs, that prevents a baserunner from proceeding to a base to which he is entitled because of a home run or other awarded base, a substitute baserunner shall be permitted to take his place and complete the play.

EFFECT Sec. 7 A-H When a batter or baserunner is awarded one or more bases, each base must be touched in regular order when advancing, otherwise the team in the field may make an appeal on the baserunner.

Sec. 8 A BASERUNNER MAY BE PUT OUT IF:

A. While the ball is in play, he fails to touch each base in legal order before attempting to advance to the next base. Either the baserunner at first base, or any other baserunner forced to advance, because the batter became a baserunner is considered as a force-out, should an appeal be made.

B. After reaching first base, the batter-baserunner's momentum causes him to overrun or overslide first base, the batter-baserunner then makes an attempt to start toward second base, before returning to retouch first base.

C. After dislodging a base, the runner attempts to continue to the next base.

D. If a fair ball is trapped.

Sec. 9 BASERUNNERS MAY AND SHALL RETURN TO BASES AT VARIOUS TIMES:

A. Baserunners required to return, or attempting to return when the ball is in play, must touch each base in regular legal reverse order. If a batter-baserunner or baserunner abandons a base and enters his team area or leaves the field of play, the batter-baserunner or baserunner shall be declared out immediately when he enters his team area or leaves the field of play.

EFFECT Sec. 9 A

1. Batter-baserunners or baserunners are in jeopardy until they get back to their base when the ball is alive.

2. A baserunner may not return to a preceding base, after the ball has been declared dead, if he has touched a succeeding base, or after a following baserunner has scored.

3. A baserunner may not return to retouch a missed base after a following runner has scored.

B. Two baserunners may not occupy the same base simultaneously.

EFFECT Sec. 9 B The first baserunner touching a base shall be entitled to occupy it until he has touched the next base legally, or is forced to leave the base due to the batter becoming a baserunner. The following baserunner may be put out by being tagged with the ball.

C. A baserunner shall not run bases in reverse order so as to confuse the fielders, or to make a travesty of the game.

EFFECT Sec. 9 C The baserunner shall be declared out and the ball is dead.

D. A batter-baserunner or baserunner may not return to touch a missed base or one he had left illegally, once he enters his team area or out of play territory.

EFFECT Sec. 9 D Once a batter-baserunner or baserunner, who has not yet been declared out, enters his team area or out of play territory and returns to the field of play in an attempt to touch a missed base, he is to be called out immediately.

Sec. 10 BASERUNNERS MUST RETURN TO THEIR BASES:

A. If a foul ball is caught illegally.

B. When a ball is batted illegally.

C. When a batter or baserunner causes interference, all baserunners must return to the last base legally touched at the time of the interference.

D. When an umpire or baserunner is struck by a fair batted ball, before it passes a fielder, excluding the pitcher, unless of course, in the umpire's judgement, no fielder had a chance to play the ball.

E. When time out is called by the umpire.

EFFECT Sec. 10 A-E

1. The ball is immediately dead.

2. Baserunners may be forced to advance, if the batter is credited with a hit under part "D" thus awarded first base.

3. Baserunners need not touch intervening bases, when required to return.

4. Baserunners must be allowed sufficient time to return, when required.

Sec. 11 BASE STEALING OR ADVANCING IS NOT PERMITTED AS A RESULT OF ANY PITCHED BALL NOT HIT

EFFECT Sec. 11 If a baserunner fails to keep contact with the base to which he is entitled until a pitched ball has bounced in front of, reached or passed the home plate / strike mat or is batted, the ball is immediately dead, "**No Pitch**" is called and the baserunner is declared out. Baserunners who have left the base legally (after a pitched ball has bounced in front of, reached or passed the home plate / strike mat) but the ball has not been hit, are not declared out, but must immediately return to their base and the ball is dead.

Sec. 12 BASERUNNERS ARE NOT OUT:

A. When a batter-baserunner overruns or overslides first base and immediately returns to that base.

B. When a baserunner is required to return to a base and is not given sufficient time to return.

C. When a baserunner is touched with the ball not securely held by a fielder.

D. When a defensive team does not attempt an appeal play until after a next pitch is made.

E. When a baserunner holds his base until a fly ball is touched, and then attempts to advance.

F. When a baserunner runs outside a baseline and behind a fielder attempting to field a batted ball.

G. When a baserunner runs outside the baseline, other than to avoid a fielder attempting to tag him with the ball.

H. When a baserunner is hit by a fair batted ball that has passed through or past a fielder, including the pitcher, and no other fielder is in position to field the ball.

- I. When a baserunner makes contact with a fielder not fielding the ball.
- J. When a baserunner sliding into a base, dislodges the base from its proper position.
- K. When, while in contact with the base, a baserunner is hit with a fair batted ball, unless the umpire rules that the ball was intentionally interfered with, or a fielder was interfered with, while attempting to field a ball.

EFFECT Sec. 12 K The ball remains alive with all baserunners continuing to be in jeopardy.

- L. When a baserunner is hit by a fair batted ball, after it is touched or touches any fielder, including the pitcher.

Sec. 13 CHARGED CONFERENCES Only two (2) charged conferences may take place between the manager or other team representatives and the batter or baserunner in an inning. Umpires shall not allow any such conferences in excess of two (2) in an inning.

EFFECT Sec. 13 A A manager or coach who insists on another charged conference shall be ejected from the game.

Sec. 14 COMMITMENT LINES/SCORING LINE – When applicable (with Commitment Line and Scoring Line Rules being applied – in all divisions and categories):

- A. There is to be no sliding while attempting to touch and/or cross the scoring line at any time.

EFFECT Sec. 14 A A player is to be called out if he slides while attempting to touch and/or cross the scoring line, at the home plate / strike mat.

- B. Sliding may occur at all other bases.

- C. A baserunner who touches the **COMMITMENT LINE** or makes contact with the ground past the **COMMITMENT LINE** with any part of the body between third base and the scoring line at the home plate / strike mat must continue on towards the scoring line (at the home plate /strike mat).

EFFECT Sec. 14 C A player who has touched and/or crossed over the commitment line as described above and attempts to return to third base, shall be declared out. The ball is alive and all baserunners are in jeopardy.

- D. A baserunner may be tagged out between the commitment line and the scoring line.

- E. All baserunners attempting to score a run must do so by touching the **SCORING LINE** with one foot or by placing one foot on the ground past the **SCORING LINE** in foul territory, in order for it to be counted as a run.

EFFECT Sec. 14 E Runners are out if they touch the home plate / strike mat or cross over the home plate / strike mat in fair territory, whether a play is made or not.

- F. The baserunner should avoid all collisions or be subject to ejection, based on the umpires' judgement.

Sec. 15 COURTESY RUNNERS may be used (provided the batter has safely reached base) a maximum of three (3) times per game in all divisions except Master and Senior, who may use a maximum of seven (7) courtesy runners per game. Seniors 60+ and 65+ can have unlimited use of courtesy runners with no penalty. When courtesy runners are used, in any division, the same runner cannot be used more than once except seniors 60+ and 65+. Only players listed on the line-up card are eligible to be courtesy runners and a courtesy runner can be used for a courtesy runner. If there are no courtesy runners or substitutions available to take the place of a courtesy runner that is on base when that player is to be up to bat, an out shall be declared.

EFFECT Sec. 15 Failure of the manager or team representative to notify the plate umpire that a courtesy runner is being used, and there is an appeal by the opposing team, the courtesy runner /baserunner shall be called out.

NOTE: The use of a courtesy runner does not constitute a substitution. Where a courtesy runner is used in coed categories, a male must be placed for a male, a female for a female, or a female for a male.

SLO-PITCH NATIONAL CHAMPIONS • 1990-2015

MENS A

2015-Pharmapar, QC
 2014-HR Sports Orioles, ON
 2013-HR Sports Brewins, ON
 2012-Home Run Sports/Miken/
 PT Brewins, ON
 2011-Ting's Moving/Mizuno/Home
 Run Sports Orioles, ON
 2009-MOMO Sports, QC
 2008-Transat / Novopharm, QC
 2007-Air Transat, QC
 2005-South Essex, ON
 2004-Easton Prostock, BC
 2003-Yankees, ON
 2002-Easton Enervest Canadians, AB
 2001-Legends, MB
 2000-Delta Cubs, BC
 1999-R & R Orioles TPS, ON
 1998-Team Bud, ON
 1996-Sprint, ON
 1995-Easton's Hub City Sports, SK
 1994-KW Dodgers, ON
 1993-Olympic Hurlers, SK
 1992-Olympic Hurlers, SK
 1991-TPS, ON
 1990-Mulberry A, ON

MENS B

2015-Saskatoon Crush, SK
 2014-DeMarini D-Birds, NS
 2013-Rockies, ON
 2010-Red Lite, QC
 2009-BC Jays, BC
 2008-Rainiers, BC
 2007-Athletics, SK
 2006-Karma, MB
 2005-OSI Astros, ON
 2004-Quest, BC
 2003-AW Fireguard/DeMarini
 Steelers, BC
 2002-Blyth Storm, ON
 2001-Easton Connexion, ON
 2000-Gashouse Gang, ON
 1999-PA Braves, SK
 1998-Chickenhawks, ON
 1997-Bulldogs, MB
 1996-Hi-Test, Por, BC
 1995-FX, ON
 1994-Dorchester Sportswear, ON
 1993-Sutton Group, ON
 1992-Thamesville Shots, ON
 1991-Hi-Test, BC
 1990-Batmen, BC

MENS C

2015-ODB, ON
 2014-Bus Drivers, BC
 2013-Stunners, SK
 2012-Halifax Mojo/Tyja Dirty
 Birds, NS
 2011-Niagara Chiefs, ON
 2010-Prairie Brewers, SK

2009-Red Lite, QC
 2008-Coors Lite / MNB Softball, NB
 2007-Kibosh, ON
 2006-360 Freaks, ON
 2005-Stubby's, ON
 2004-Sundance, NL
 2003-Enviro Vac
 Bat-Heater.com, BC
 2002-Moncton Moosehead Light, NB
 2001-Easton Hurricanes, BC
 2000-Sundance, NL
 1999-Ottawa Wildcats, ON
 1998-Just Brew It Brewers, BC
 1997-Southampton Farmers, NS
 1996-Clairemont Classics, ON
 1995-Air-Transat Worth, QC
 1994-Thousand Island Brew Jays, ON
 1993-Sprint Red Eyes, ON
 1992-Rocky Hill Farms, ON
 1991-Vito Twins, NB
 1990-Michigan Tavern, ON

MENS D

2015-Les Cardinals de
 St. Hyacinthe, QC
 2014-BroJayz, NS
 2013-Juiced, ON
 2012-Phillies, ON
 2011-Johnson, AB
 2010-Hitmen Reloaded, QC
 2009-Team Grip, ON
 2008-Average Joes, ON
 2007-IGA Extra, QC
 2006-Butlers Construction, NS
 2005-Crush, SK
 2004-Team Express, ON
 2003-Dockstader Sports, BC
 2002-Marionville 99ers, ON
 2001-Corbett's, ON
 2000-Last Call, ON
 1999-Allied Sharks, ON
 1998-Crunch, BC
 1997-Prairie Fire, SK
 1996-Get A Grip, ON
 1995-TJ Scaletta, ON
 1994-Kennedy Cubs, BC
 1993-Harmattan Olds, AB
 1992-Bar Tonio Et CBC
 Construction, QC
 1991-ITT Aimco Brownbears, ON
 1990-Rocky Hill Farm, ON

MENS E

2015-Spryfield Blue Hats, NS
 2014-Paperworks Pounders, MB
 2013-Glace Bay Royals, NS
 2012-Mariners - Musquodoboit,
 NS 2011-Motorboaters, ON
 2010-Blacksox, BC
 2009-St. Anthony, NL
 2008-Manwhores, ON
 2007-Parsboro Flares, NB

2006-River Dogs, ON
 2005-Gamblers, ON
 2004-Antirouille, QC
 2003-Breezers, QC
 2002-Stunners, SK
 2001-Big Guys, NS
 2000-Slo-Pokes, AB
 1999-Sluggers, ON
 1998-Parrsboro Selects, NS
 1997-Possible Wolverines, ON
 1996-Chixdigus, MB
 1995-Ampro Electric, ON
 1994-Labatts Lite, NL
 1993-T.B.T. Electric, ON
 1992-KG Westerners, SK
MENS 35COMP
 2000-Ward & Patch, ON
 1997-Direct Hit, ON
 1996-Stubby's, ON
 1995-Angry Raisins, AB
 1994-Spitz, BC
 1993-Gencorp, ON
 1992-Primetime, AB
 1991-Champs Bar & Grill, ON
 1990-Oshawa Sox, ON
MENS 35D
 2015-AFN Softball, NL
MENS 35E
 2015-Red Sox, SK
MENS 35IM/REC
 2001-35I-Karlee's Beer Nuts, ON
 2000-35I-Dr. Stucco, AB
 1999-35I-Men-O-Paws, ON
 1998-35I-Pollard Roofing, ON
 1997-35I-Looker Office
 Equipment, AB
 1995-35I-Calgary Brewers, AB
 1994-35R-Tri-K Drilling, BC
 1993-35R-Stubby's, ON
 1992-35R-Barons, BC
MENS 40COMP
 2014-Voodoo, AB
 2013-Pharmapar, QC
 2012-Pharmapar, QC
 2011-Pharmapat Combat, QC
 2010-Toxxxic, AB
 2009-Driving Force, BC
 2008-Driving Force, BC
 2007-Stubby's, ON
 2006-Bandits, ON
 2005-Bandits, ON
 2004-Pollard 40, ON
 2003-Stubby's, ON
 2002-Enviro Vac /
 Bat-Heater.com, BC
 2001-Venture Steel, ON
 2000-Enviro-VacEqualizer Bats, BC
 1999-Angry Raisins, AB
 1998-Rhino's, BC
 1997-Enviro-Vac Hotsticks, BC

SLO-PITCH NATIONAL CHAMPIONS • 1990-2015

1996-All Star Mechanical, BC
1995-Sarnia Hose, ON
1994-Tournament Sports, ON
1993-All Star Mechanical, BC
1992-Tournament Sports, ON
1991-Molson Canadians, BC
1990-R.W. Clothing, ON

MENS 40IM

2014-Saskatoon Athletics, SK
2013-AFN Softball, NL
2012-Meineke, ON
2011-Titans, AB
2010-Fog, SK
2009-Black Horse, NL
2008-Fat Boys
2007-She Said I Could Play, ON
2006-Tigers, ON
2005-Coles Trucking, ON
2004-Angry Raisins, AB
2003-Gator Ted's Blues, ON
2002-Quickcard Angry Raisins, AB
2001-Blue Devils, SK
2000-Sunshine Asparagus, ON
1999-Langley Express, BC
1998-Sarnia Hose & Hydraulic, ON
1997-Burnaby Barons, BC
1996-Dakotans, MB
1995-Hotel LaSalle, ON

MENS 40/REC

2004-North End Pub, NS
2003-EK Dinosaurs, MB
2002-Adams Lumber, SK
1994-Old Spikes, SK
1999-Allied Sharks, ON
1992-Kelseys Classics, ON

MENS 45IM

2000-Burnaby Barons, BC

MENS 50COMP

2013-Bandits, ON
2011-Redline, AB
2009-Bandits, ON
2008-Easton, AB
2007-Envirovac, BC
2006-Time Out, ON
2005-Barons, BC
2004-Barons, BC
2003-Barons, BC
2002-Sunshine Asparagus, ON
2001-Brantford Nissan 50, ON
2000-Huskies, AB
1999-Ancient Mariners, AB
1998-Brantford Nissan, ON
1997-Brantford Nissan, ON
1996-Brantford Nissan, ON
1995-St. Albert White Sox, AB
1994-St. Albert White Sox, AB
1993-Brantford Nissan, ON
1992-Royal City Fireman, BC
1991-Richmond Olde Boys, BC

MENS 50IM

2015-Brantford Nissan, ON
2014-Fatty Patty's, ON
2013-Fatty Patty's, ON
2012-She Said I Could Play, ON
2011-Brantford Nissan, ON
2010-Blazers, AB
2009-Fat Boys, AB
2008-Emporium, ON
2015-Force 50, ON
2014-B&B Electric, NL
2013-Simcoe Old Ballers, ON
2012-Mckinley Funeral Homes, ON
2011-CBS Crotty's, NL
2007-MB Classics, MB
2006-Carr's Shell, ON
2005-Classics, MB
2004-Rockin 50's, ON
2003-Cambridge Classics 50+, MB

MENS 55

2012-Easton Redline, AB
2010-Burnaby Barons, BC
2009-Barons, BC
2008-Buzzards, AB
2007-Windsor Chiefs, ON
2006-Windsor Sr. Chiefs, ON
2005-Windsor Sr. Chiefs, ON
2004-Windsor Sr. Chiefs, ON
2003-Brantford Nissan 55's, ON
2002-Tottenham Merchants 55's, ON
2001-Brantford Nissan, ON
2000-White Sox, AB
1999-Windsor Sr. Chiefs, ON
1998-St. Albert Old Sox, AB
1997-St. Albert Poor Boys, AB
1996-Ogopogo 55, BC
1995-Ogopogo 55, BC
1994-Richmond Olde Boys, BC
1993-Kent Refrigeration Die Hards, ON
1992-St. Albert Poor Boys, AB
1991-Edmonton Greens, AB

MENS 60

2015-Carr's Shell, ON
2014-Prairie Combines, AB
2013-Hub Trophies, NL
2012-Manitoba Classics, MB
2011-Old Buzzards, AB
2010-Marauders, BC
2009-Windsor Chiefs, ON
2008-Lillydale White Sox, AB
2007-Sports Traders, MB
2006-St. Albert White Sox, AB
2005-Royal City Fire, BC
2004-Moonraker Pub, BC
2003-St. Albert White Sox, BC
2002-Brantford Nissan 60's, ON
1998-Alta Auto Antiques, AB

MENS 65

2011-Silver Foxes, SK
2010-St. Albert White Sox, AB
2009-Brantford Nissan, ON
2007-Golden Dynasty Relics, AB
2015-Home Run Sports Ladybirds, ON
2014-Miken Freaks, ON
2013-HR Sports Lady Birds, ON
2012-Northern Impact, ON
2011-Mizuno Home Run Sports Lady Birds, ON
2009-Priceless, ON
2008-Priceless, ON
2007-Higgins Proteam, ON
2005-Bison Blondes, MB
2004-Bison Blondes, MB
2003-Jockey Canada, ON
2002-Beirman's Club, QC
2001-Kelowna Extreme, BC
2000-Acotech TPS, SK
1999-La Clinique Du Sport, QC
1998-Devils, ON
1996-TNT, BC
1994-Just Ladies, ON
1992-Sisters, ON
1991-Union Station Barsharks, ON
1990-Golden Horseshoes, ON

WOMENS B

2013-Fusion, BC
2010-Gators, BC
2009-Bandits, ON
2008-Trail X Press, SK
2007-Bullets, ON
2006-Trail-X Express, SK
2005-Cougs, BC
2003-Crush, ON
2002-Cheers, BC
2001-Depencier Builders, ON
2000-On Call Internet Rookies, BC
1999-Predators, SK
1998-Pizza Hut, ON
1997-TGI Fridays, ON
1996-Devils, ON
1995-Lakers, AB
1994-Rockford Peaches, ON
1993-Lightning, ON
1992-T.I.M., QC
1991-A & L Auto Recyclers/Kelsey's, ON
1990-Gaetz Gators, ON
2015-Not Just a Pretty Face, ON
2014-Halifax Heat, NS
2013-Bubba's, ON
2012-Blitz, ON
2011-Valley Vixens, NS
2010-Diamond Dozen, MB

WOMENS C

SLO-PITCH NATIONAL CHAMPIONS • 1990-2015

- 2009-Trolls, BC
 2008-Rebels, QC
 2007-Health Angels, SK
 2006-Dooleys, NL
 2005-Pierre Roux Sports, QC
 2004-Budz, BC
 2003-3 D's, ON
 2002-Sisters of Swing, BC
 2001-Down Unders, BC
 2000-Sliders, ON
 1999-County Crows, ON
 1998-Commanche Sharks, AB
 1997-Sarnia Steelers, ON
 1996-P.A.W.S., SK
 1995-Rendezvous Rebels, ON
 1994-Grand Union Tavern, ON
 1993-Diamonds, MB
 1992-Les Esponges Restaurant, QC
 1991-Enchant Soxettes, AB
 1990-CBD Hummers, ON
- WOMENS D/E**
- 2015-Caught Looking, ON
 2014-Black Widow, MB
 2013-Barking Parrot Boozers, BC
 2012-Hammersma Masonry, ON
 2011-Blitz, ON
 2010-Furay, ON
 2009-Outdoor Kidz, ON
 2008-Fixer's Bar, MB
 2007-Gators, BC
 2006-Fireballs, NB
 2005-Rhymes With Delores, SK
 2004-Kynock Diggers, NS
 2003-Quest, ON
 2002-Halifax Explosion, NS
 2001-O'Brien's Ladies Slo-Pitch, ON
 2000-Roxy, ON
 1999-WD-Pickellettes, ON
 1998-WD-Kynock Diggers, NS
 1997-WD-Dorner Ladies Ball Team, ON
 1996-WD-Onoway Red Snappers, AB
 1995-WD-Dover II, ON
 1994-WD-Big Woodies, MB
 1993-WR-Stanley Pub, NL
 1992-WR-Molson Paradise, NL
- WOMENS 35**
- 2015-WFC, AB
 2013-New Moon, NL
 2012-Angry Birds, BC
 2011-Saucony, ON
 2010-Saucony, ON
 2009-Boston Pizza, ON
 2008-Stixx, AB
 2007-Bandits, ON
 2006-Bandits, ON
 2005-Pete's Sports Fossils, ON
 2004-Pete's Sports Fossils, ON
 2003-Z Dot Dot, ON
 2002-TNT Tigers, BC
 2001-Chip-A-Way, ON
- 2000-Dockstader Sports, BC
 1999-All-Star Mechanical TNT, BC
 1998-Still Hangin In There, ON
 1997-TNT, BC
 1996-One Foot In., ON
 1995-Catherwoods Bad Girls, ON
- COED COMP**
- 2011-Phiten, ON
 2008-Roll 2, BC
 2006-Bush Monsters, NS
 2005-CJC, QC
 2004-Tyrt, BC
 2003-Taz, BC
 2002-PIAS, ON
 2001-Langley Concrete Magic, BC
 2000-Crunch, BC
 1999-Sock Exchange, BC
 1998-Easton Reflex, ON
 1996-Ottawa Tribe, ON
 1995-Orillia Merchants, ON
- COED B**
- 2004-Bigger Is Better, BC
 2003-CJC 2000, QC
 2002-Commercial Hotel Fun Police, BC
 2001-Blasters, ON
 2000-Lock N Load, ON
 1999-Perfect Blend, AB
 1998-Falcons, ON
 1997-Papa G & The Pack, SK
 1996-Sock Exchange, BC
 1995-Undermount Tavern, ON
 1994-Oak & Carriage Pub, BC
 1993-Anything Goes, ON
 1992-Shakey Shakers, ON
 1991-Eraserheads, BC
- COED C**
- 2014-Beaman's Auto Maniacs, NS
 2013-Vicious & Delicious, ON
 2012-Train Wreck, AB
 2011-Roots, AB
 2010-Oxygen, ON
 2009-Osprey, BC
 2008-Mullets, MB
 2007-Bombsquad, ON
 2006-Exmark, BC
 2005-Titans, BC
 2004-Clarke's Harbour Foggies, NS
 2003-Trump Mooses, MB
 2002-Taz, BC
 2001-Bar Vocalz, QC
 2000-CISA TV, AB
 1999-Diamond Backs, ON
 1998-Dawgz, BC
 1997-Perfect Blend, AB
 1996-Sackville Pizza & Donair Hawks, NS
 1995-Bedrock Blue Pterodactyls, SK
 1994-Moosehead Dream Team, NS
 1993-Thunderstuck, AB
- 1992-Jack Astors, ON
- COED D**
- 2015-Happy Endings, ON
 2014-Wrecking Crew, AB
 2013-Nataire Isabelle Dumont, QC
 2012-Steelers, SK
 2011-Blue Angels, ON
 2010-Millet Allstars, AB
 2009-Royals, SK
 2008-Odds N Ends, ON
 2007-Stacked, ON
 2006-The Fuze, SK
 2005-Less Rage, BC
 2004-Oxygen, ON
 2003-Roadkill, ON
 2002-Advocates, ON
 2001-Pencils, AB
 2000-Hayes Hawks, NS
 1999-Young Guns, SK
 1998-Four Ports Marine, PEI
 1997-Donegals Pub, BC
 1996-Perfect Blend, AB
 1995-Stop 17, ON
 1994-Dialtel, ON
 1993-PA Bottlers, SK
 1992-Yorkton Bandits, SK
- COED E**
- 2015-The Future, NS
 2014-The Runs, MB
 2013-Thunder, QC
 2012-All Nations, MB
 2011-Yetmans Shingles, NL
 2010-Tornados Restaurant, MB
 2009-Buccaneers, ON
 2008-Arlie C Feron, QC
 2007-Langley Riders, BC
 2006-Dal's/UKJ, MB
 2005-Dooly's Blue Arse Flies, NF
 2004-Courtesy Brains, MB
 2003-Fuze, SK
 2002-Taz, BC
 2001-Athletics, ON
 2000-On The Edge, ON
 1999-Ottawa Possee, ON
 1998-London Drug Raptors, BC
 1997-Bad News Bears, AB
 1996-Rebels, AB
 1995-Estevan Fine Foods, SK
 1994-Cameco Field Jokers, SK
 1993-Last Call, AB
 1992-Rockers, AB
 1991-Strokin, MB
 1990-Golden Dept., BC
- COED C SIGNATURE SERIES**
- 2015-Osprey, BC
- COED D SIGNATURE SERIES**
- 2015-Cruisin Auto Giants, AB
- COED E SIGNATURE SERIES**
- 2015-K.P.'s, AB

2016 / 2017 Molson Slo-Pitch National Championship Locations

July 28 - Aug. 1, 2016

Mens A - Orillia, ON (June 24-26)
Mens B - Calgary, AB
Mens C - Niagara Falls, ON
Mens D - Kelowna, BC
Mens E - Niagara Falls, ON
Mens 35 Comp - Calgary, AB
Mens 35 C - Kelowna, BC
Mens 35 D - St. John's. NL
Mens 35 E - Niagara Falls, ON
Mens 50 Comp - St. John's. NL
Mens 50 IM - St. John's. NL
Mens 50 E - St. John's. NL
Mens 60 - St. John's. NL

Womens A - Orillia, ON (June 24-26)
Womens B - Calgary, AB
Womens C - Niagara Falls, ON
Womens D - Kelowna, BC
Womens 35 - St. John's. NL

Coed Comp - Niagara Falls, ON
Coed C - Niagara Falls, ON
Coed D - Niagara Falls, ON
Coed E - Niagara Falls, ON

SIGNATURE SERIES

Coed Comp - Calgary, AB
Coed C - Calgary, AB
Coed D - Calgary, AB
Coed E - Calgary, AB

Aug. 3 - 7, 2017

Mens A - Orillia, ON (Date T.B.A.)
Mens B - Winnipeg, MB
Mens C - Moncton, NB
Mens D - Winnipeg, MB
Mens E - Moncton, NB
Mens 35 Comp - Saskatoon, SK
Mens 35 C - Saskatoon, SK
Mens 35 D - Saskatoon, SK
Mens 35 E - Saskatoon, SK
Mens 50 Comp - Saskatoon, SK
Mens 50 IM - Saskatoon, SK
Mens 50 E - Saskatoon, SK
Mens 60 - Saskatoon, SK

Womens A - Orillia, ON (Date T.B.A.)
Womens B - Moncton, NB
Womens C - Moncton, NB
Womens D - Winnipeg, MB
Womens 35 - T.B.A., AB

Coed Comp - Moncton, NB
Coed C - Winnipeg, MB
Coed D - Moncton, NB
Coed E - Winnipeg, MB

SIGNATURE SERIES

Coed Comp - Langley, BC
Coed C - Langley, BC
Coed D - Langley, BC
Coed E - Langley, BC

**COME OUT & JOIN IN THE
FUN!**

**Special Events, All-Star Games,
Individual & Team Events,
Social Gatherings!**



RULE 9. - BALL IN PLAY (LIVE) & DEAD BALL

Sec. 1 THE BALL IS LEGALLY PUT IN PLAY BY THE UMPIRE:

- A. At the start of the game and each half inning when the pitcher has the ball while standing in his pitching position and the plate umpire has called **"PLAY BALL"**.
- B. After every dead ball situation.

Sec. 2 THE BALL IS DECLARED LIVE AND IN PLAY:

- A. When the pitcher has the ball in his possession within the pitching zone.
- B. When the pitcher delivers the pitch toward the home plate / strike mat.
- C. When the batter hits the pitched ball legally.
- D. Whenever there is a play resulting from the legally batted ball.
- E. When a live ball strikes a photographer, groundskeeper, policeman, etc., when they are assigned to the game. If they are within playable territory, they become part of the field.
- F. When a fly ball, either fair or foul, including a line drive or foul tip, is legally caught.
- G. At all times during the enforcement of an infield fly rule.
- H. When any thrown ball goes into foul territory and is not blocked.
- I. When a batted or thrown live ball accidentally strikes the coach.
- J. If thrown, it strikes an umpire or offensive player.
- K. When a fair batted ball strikes an umpire or baserunner after touching a fielder, or after passing any fielder including the pitcher/infielder.
- L. When a fair ball strikes the umpire or offensive player on foul ground.
- M. If baserunners have reached the base to which they are entitled when a fielder illegally touched or fielded a batted or thrown ball.
- N. When a delayed obstruction call has been made and signaled but not yet enforced.
- O. When a baserunner must return to a base in reverse order while the ball is alive and in play.
- P. When a baserunner is called out for passing a preceding runner.
- Q. When a baserunner acquires the right to a base by legally touching it before being put out.
- R. When a base is dislodged while baserunners are progressing around the bases.
- S. When a baserunner is called out for running more than three (3) feet outside the established base path in order to avoid a tag.
- T. When a baserunner is forced or tagged out.
- U. When a "live ball" appeal play is involved or enforced.
- V. When a player is called out under the profanity rule.
- W. Whenever the ball is not **"DEAD"**, as provided in Section 3 of this rule.
- X. When a coach physically holds or pushes a baserunner to assist him to return or to leave a base.

Sec. 3 THE BALL IS DEAD AND NOT IN PLAY:

- A. When no pitch is declared.
- B. When an illegal pitcher's action is declared.
- C. When a baserunner is called out for leaving a base too soon, on a pitched ball.
- D. After each called "ball" or "strike".
- E. When a pitched ball touches any part of a batter's person.
- F. When a batter bats illegally, or hits the ball with an illegal bat.
- G. When a batter **DELIBERATELY** bunts or chops the ball downward.
- H. When the batter is hit by his own batted ball, either fair or foul.
- I. When a foul ball is not caught on the fly. Baserunners may not advance, including runners who have touched and/or crossed the commitment line.
- J. When a batter steps completely across the home plate / strike mat, with the pitcher standing within the pitching zone.

EFFECT Sec. 3 A-J Ball is immediately dead. Baserunners may not advance.

- K. If a fielder or infielder intentionally drops a fair fly ball or line drive.
- L. When an offensive team member causes interference.
- M. When the baserunner deliberately crashes into a defensive player, who is waiting to make a tag.
- N. When a baserunner is off a base and is hit with a fair batted ball, before the ball is touched by or passes through the infielders and provided an infielder had the opportunity to make a play.
- O. When a blocked ball occurs.
- P. When a ball lands outside the established limits of the playing field.
- Q. When a coach intentionally interferes with a batted or live thrown ball.
- R. When a ball is caught illegally.
- S. When a spectator or other person, not in the game, causes interference.
- T. When a batted ball hits an umpire before the ball is touched by or passes an infielder.
- U. When "TIME" is called for any reason by the umpire.
- V. When there is obstruction on the batter and it is enforced.

EFFECT Sec. 3 K-V The ball is immediately dead. Baserunners are permitted to remain on the bases they attained prior to the infraction and then subsequently advance, if applicable, to the bases awarded as a result of the infraction.

Metric Conversions

The following table will assist with the Metric Conversion of information contained in these Rules.

1/32	0.7938 mm	16 feet	487.68 cm
1 inch	2.54 cm	25 feet	762.00 cm
2-1/4 inches	5.72 cm	30 feet	914.00 cm
4 inches	10.16 cm	32 feet	975.00 cm
5 inches	12.70 cm	32 feet 5 inches	990.60 cm
6 inches	15.24 cm	35 feet	1067 cm
8 inches	20.32cm	38 feet	1168 cm
8-1/2 inches	21.59 cm	40 feet	1219 cm
10 inches	25.40 cm	42 feet	1280 cm
11 inches	27.94 cm	45 feet	1371 cm
11-7/8 inches	30.16 cm	46 feet	1402 cm
12 inches	30.48 cm	50 feet	1524 cm
12-1/8 inches	30.80 cm	55 feet	1676 cm
15 inches	38.10 cm	60 feet	1829 cm
15-3/4 inches	38.74 cm	65 feet	1981 cm
16-1/4 inches	41.28 cm	70 feet	2134 cm
17 inches	43.18 cm	84 feet 10-3/4 inches	2586 cm
24 inches	60.96 cm	91 feet 11 inches	2802 cm
30 inches	76.20 cm	99 feet	3017 cm
34 inches	86.36 cm	120 feet	3658 cm
36 inches	91.44 cm	130 feet	3962 cm
48 inches	121.92 cm	140 feet	4267 cm
60 inches	152.40 cm	200 feet	6096 cm
84 inches	213.36 cm	225 feet	6858 cm
2 feet 5 inches	73.66 cm	245 feet	7468 cm
2 feet 6 inches	76.20 cm	250 feet	7620 cm
3 feet	91.44 cm	265 feet	8077 cm
4 feet	121.92 cm	275 feet	8382 cm
5 feet	152.40 cm	300 feet	9144 cm
7 feet	213.36 cm	6-1/4 ounces	177.19 gm
8 feet	243.84 cm	7 ounces	198.45 gm
8 feet 5 inches	256.54 cm	9 ounces	255.15 gm
10 feet	304.80 cm	10 ounces	283.50 gm
12 feet	365.76 cm	38 ounces	1077.30 gm
15 feet	457.00 cm		



official supplier to SPN UMPIRES



HOME RUN SPORTS

**GET READY
FOR YOUR GAME.**

Canadian owned & operated since 1986

EQUIPMENT, UNIFORMS & TEAM CLOTHING

Baseball Softball Slopitch Hockey Football Soccer Volleyball Basketball

WINNIPEG | MISSISSAUGA | LONDON | CALGARY | EDMONTON

*join us for exclusive
savings & current promos*

facebook.com/hrsports
twitter.com/HomeRunSports



Brand New
WEBSITE
coming for
the 2016
season!



RULE 10. - UMPIRES

Sec. 1 POWERS AND DUTIES: Umpires are the representatives of the organization or league by which they have been engaged or assigned to a particular game, and as such are **AUTHORIZED AND REQUIRED** to enforce each and every section of these rules, from beginning to the end.

EFFECT Sec. 1 Umpires have the power, and should use it with discretion, to order a manager, coach, captain or player to do or to cease doing any act which in their judgement is necessary to give force and effect to one and all of these rules, and to enforce penalties as herein prescribed. The plate umpire, in consultation with his fellow umpires, if appropriate, shall have the authority to make decisions on any situations not specifically covered in the rules.

Sec. 2 UMPIRE ELIGIBILITY:

- A. Umpires must be currently carded umpires in good standing with Slo-Pitch National.
- B. Umpires must be a minimum of eighteen (18) years of age in order to be carded. For safety reasons, there will be no exceptions to this rule.

Sec. 3 GENERAL INFORMATION & REGULATIONS FOR UMPIRES

- A. The umpire should not be connected in any way with either team.
 - B. The umpire should be sure of the date, time and location of the game.
 - C. The umpire should arrive at the field 30 minutes before the game time to mentally and physically prepare for the game.
 - D. The umpire shall wear a uniform which will allow freedom of movement and which will be:
 - 1. Light grey or red short sleeved golf shirt bearing the official SPN umpire logo.
 - 2. Light grey t-shirt bearing the official SPN umpire logo.
 - 3. Light grey shorts or light grey pants.
- NOTE:** See STG&OR for uniform requirements at Provincial/Regional and National Championships.
- 4. Long bill red hat, embroidered with SPN umpire in black letters.
 - 5. Grey ball bag and a black belt.
 - 6. Grey socks with pants and white socks with shorts.
 - 7. Black shoes to be worn with grey pants, and white or black shoes may be worn with grey shorts.
 - 8. Black windbreaker bearing the official SPN umpire logo.
 - 9. Black crew neck sweater bearing the official SPN umpire logo.
 - 10. Black rain suit bearing the official SPN umpire logo – optional for inclement weather. Official Uniform must be worn underneath.

NOTE: When more than one umpire is working a game, both umpires must be attired in the same uniform.

- E. The umpire shall have all necessary equipment deemed proper (umpire's indicator, a bat ring, small whisk broom and all proper protective equipment such as an athletic support, a mask when required) . He is to ensure that all his equipment not being used is not on the playing field.
- F. The umpire(s) will introduce themselves to the official scorekeeper and managers.
- G. The umpire(s) must inspect the playing field and equipment, and supplement the rule book, when possible, with written game ground rules, indicating all out-of-play areas, or other exceptions to the rulebook for both managers.
- H. The umpire working behind the home plate / strike mat judging the pitched balls shall be designated as the Plate Umpire, with the umpire judging plays on the bases to be called the Base Umpire.
- I. Neither umpire has the authority to set aside a decision made by the other umpire within the limits or scope of his respective duties as outlined in these rules.
- J. Under no circumstances shall either umpire seek to reverse a decision made by his associate, nor shall either umpire criticize or interfere with the duties of his associate.

- K. An umpire may consult with his associate at any time he desires to do so, or when requested to do so by a manager. However, the final decision shall rest with the umpire whose exclusive authority it was to make the decision and who requested the opinion of the other umpire.
- L. If different decisions should be made on one play by different umpires, the Plate Umpire shall call all umpires into consultation, with no other person present. After consultation, the plate umpire shall determine which decision shall prevail, based on which umpire was in the best position, and which decision was most likely to be correct. Play shall then proceed as if only one decision has been made.
- M. The umpires shall declare the batter-baserunner or baserunner safe or out without waiting for an appeal for such decision, in all cases where such player is safe or out in accordance with this set of rules.

EFFECT Sec. 3 M Unless appealed to, an umpire does not call a player out for having left a base too soon on a caught fly ball, or a touched and subsequently caught fly ball, failing to touch a base as required, batting out of order, or making an attempted start to go to second base after the batter-baserunner has crossed first base, as provided in these rules. No appeal will be considered or allowed, after the next pitch is made to a batter.

- N. An umpire, if first aid qualified, will only assist an injured person during a ball game if there is no other person present with the same or more qualifications than he has, and, if applicable, will release the care of the injured person, as soon as possible, to emergency personnel.
- O. Any participant (including players, managers, coaches, and umpires) on the playing field with an open wound, who is bleeding, must be removed from the playing field until the wound has been tended to and properly covered. This includes the umpire removing himself from the game. (Refer to Rule 5 Sec. 9).

Sec. 4 EITHER THE PLATE OR BASE UMPIRE SHALL HAVE EQUAL AUTHORITY TO:

- A. Call illegal pitcher's actions or illegally delivered pitches.
- B. Call a baserunner out for leaving a base too soon.
- C. Remove a manager, coach, player or team member for violating these rules.
- D. Call "**TIME**" when play should be suspended.
- E. Order field lights turned on.
- F. Call illegally caught balls.

Sec. 5 SPECIFIC DUTIES TO THE PLATE UMPIRE:

- A. He shall have full responsibility for the proper conduct of the game. This will include the responsibility to make sure that all bats are checked before each game. He will also have the option of checking each bat as the batter approaches the batting area.
- B. He shall take his initial position behind the home plate / strike mat.
- C. He shall call each pitch not hit, a ball or strike.
- D. He shall call all batted balls fair or foul, and all illegally batted balls.
- E. He shall call all caught fly balls.

EXCEPTION: When the base umpire has left his position to go out and call a trapped ball.

- F. On plays which necessitate the base umpire leaving the infield, the plate umpire shall move out and assume the duties of the base umpire, such as runners touching the bases, obstruction, interference, etc.
- G. He shall determine and declare if:
 - 1. A batter bunts or chops the pitched ball downward.
 - 2. A fly ball is an infield fly.
 - 3. A batted ball touches the person of the batter.
 - 4. A batter strikes at the pitch.
- H. When a **TIME LIMIT** has been set prior to game starting time, announce this fact and the time set to end the game, before the game is started. The umpire keeps this time, and total playing time of games.
- I. Inform the managers that the official scorekeeper records are official and that they, the managers, are to advise the umpire of any changes, who will in turn, advise the official scorekeeper.
- J. Should a dispute arise during or immediately following the game, ensure that the scorekeeper has the correct decision and score.
- K. He alone shall have the authority to declare a game forfeited.
- L. After a game has been started, he shall be the sole judge as to whether or not the game shall continue.
- M. He shall put the proper ball into play.

Sec. 6 SPECIFIC DUTIES OF THE BASE UMPIRE:

- A. He shall assist and cooperate with the plate umpire in order to make all proper and correct decisions.
- B. He shall take the appropriate positions on the field as outlined in the Umpire's Manual.
- C. He may and should be required to go into the outfield to call certain outfield decisions when the plate umpire would be at a great disadvantage making the call. Some of these plays would involve a trapped ball catch, fly ball hitting or clearing a fence, a legal catch when a fielder runs or falls into a fence or obstruction and drops the ball because of such a collision, and other plays, especially when light conditions are not the best.

Sec. 7 THE RESPONSIBILITIES OF ONE UMPIRE ASSIGNED TO OFFICIATE BY HIMSELF extends to all parts of the field, his duties and jurisdiction encompass all those duties normally covered when more than one umpire is assigned.

Sec. 8 UMPIRES SHALL NOT BE CHANGED DURING THE PLAYING OF A GAME, unless they become incapacitated due to an injury or illness.

Sec. 9 UMPIRE'S JUDGEMENT DECISIONS MAY NOT BE APPEALED:

- A. On a decision involving a ball or strike.
- B. On whether or not a batted ball was fair or foul.
- C. On a call of safe or out on a baserunner.
- D. When a game is called for darkness, rain, panic or other logical reasons.

EFFECT Sec. 9 A-D No decision shall be reversed by the umpire, involving his judgement, except if he is convinced he was in error. This could come from consulting another umpire working with him, as a result of his own requested conference.

Sec. 10 UMPIRES SHALL ENFORCE ALL THESE RULES:

- A. All rules governing the playing of the game are to be enforced.
- B. If, after a person has received a warning, the infractions are repeated, the umpire shall eject the offender from the game. For major offenses, no warning shall be given. An immediate ejection shall be enforced.

NOTE:

- 1. Umpires should not necessarily penalize an entire team because of the actions of one or more individuals. Remove violators from the game.
- 2. Umpires may choose not to impose a penalty when the imposition of said penalty would work to the detriment of the non-offending team.
- 3. Umpires must work together and cooperate in every way to ensure correct decisions and fair rulings.

Sec. 11 UMPIRE'S SIGNALS AND TERMS TO BE USED:

- A. To indicate the **PLAY** shall begin or be resumed, the plate umpire shall call "**PLAY**" and simultaneously make a beckoning motion for the pitcher to deliver the pitch. Extend the arm to shoulder level and directly towards the pitcher with the palm of the hand open and facing up to the sky and then bring the palm of the hand in towards your face.
- B. To indicate to the pitcher to hold the pitch **AND NOT DELIVER**, because the batter is not ready, extend the **ARM** directly toward the pitcher with an **OPEN PALM** facing the pitcher, signaling the pitcher to stop.
- C. To indicate that the **PITCH** was a **STRIKE**, the plate umpire shall raise his **RIGHT ARM** straight up above the shoulder and then down to the hammer position (right angle) with the fist closed while at the same time calling "**STRIKE**" and the number of the same in a clear and decisive voice.

- D. To indicate a **BALL**, no arm signal is used. However, the plate umpire shall give the verbal call of "**BALL**", and then add the number. If the ball lands on the plate, the umpire may indicate this by a signal using the left hand (palm open and up at chest level) and bring a closed fist (right hand) down into the palm.
- E. To indicate an **INTENTIONAL WALK** of the batter by the pitcher, the plate umpire merely makes such announcement to the batter and official scorekeeper.
- F. To indicate the **TOTAL COUNT** on the batter, the plate umpire always announces the number of **BALLS** first and then the number of **STRIKES**. Also signal the count with the hands, showing the number of **BALLS** on the left hand, and the number of **STRIKES** on the right hand.
- G. To indicate a **FOUL BALL** the umpire shall extend his hands straight up into the air while verbalizing "**FOUL BALL**" in a manner appropriate to the situation.
- H. No **FOUL TIP** indication is required.
- I. To indicate a **FAIR BALL**, the plate umpire shall gesticulate toward the centre of the diamond. **THERE IS NO VERBAL CALL.**
- J. To indicate the batter or baserunner **OUT**, the umpire shall raise his **RIGHT ARM** (hand open) straight up to a full extension directly above the shoulder and then bring it back down into the hammer position (right angle) with the fist clenched and verbally call "**OUT**".
- K. To indicate that a baserunner is **SAFE**, the umpire shall extend **BOTH ARMS** out to his sides and to shoulder level with the palms open and facing down towards the ground. A verbal call of "**SAFE**" is performed simultaneously with the signal.
- L. To indicate a **SUSPENSION** of play, the umpires shall call "**TIME**" and at the same time extend **BOTH HANDS** skyward, clearly above his head with the hands open. The other umpires shall immediately acknowledge the suspension of play, by performing a similar signal.
- M. To indicate a **DELAYED DEAD BALL**, the umpire shall extend his left arm horizontally to shoulder level and to the side.
- N. To indicate a **TRAPPED BALL**, the umpire shall extend both arms diagonally in front of his body with palms open and toward the ground and then move the arms out to the side of his body to indicate **SAFE**. "**TRAPPED BALL**" and "**SAFE**" shall be called simultaneously with the appropriate signals.
- O. To indicate a **GROUND RULE DOUBLE**, the umpire shall raise his arms straight up over the shoulder and indicate with his fingers the number of bases awarded.
- P. To indicate a **HOME RUN**, the umpire shall raise his right arm straight up over the shoulder with a clenched fist and then move the arm in a counter clockwise motion several times to indicate the home run.
- Q. To indicate a **FOUR (4) BASE AWARD**, the umpire shall raise the right arm straight up with four fingers extended and point with the left hand to the home plate / strike mat.
- R. To indicate an **INFIELD FLY RULE BEING IN EFFECT**, the umpire shall bring the palm of his right hand up to his left chest area and place the hand on the chest.
- S. To indicate an **INFIELD FLY IS NO LONGER IN EFFECT**, the umpire shall brush the fingers on the right hand down the left arm, which will be brought forward a little bit and in front of the body to indicate that it is **OFF**.
- T. To indicate an **INFIELD FLY**, the umpire shall raise his right arm straight up with his fist clenched and call "**INFIELD FLY, IF FAIR, THE BATTER IS OUT.**"
- U. To indicate that a player has been ejected from the game and the playing area, the umpire shall raise his right arm above shoulder level and point indicating that the player is to leave the playing field. The umpire will also simultaneously state in a loud voice that the player is ejected.

Sec. 12 SUSPENSION OF PLAY:

- A. The umpire may suspend play when, in his judgement, any situation or condition justifies such action.
- B. When in the opinion of the umpire all immediate play resulting from a batted ball is apparently completed, he shall call **"TIME"**.

EFFECT Sec. 12 B It is not necessary to return the ball to the pitcher, after a batted ball, to stop baserunners from advancing. When baserunners have ceased to try to move forward, or to try for the next base, because a fielder has the ball in the infield area, the umpire shall call **"TIME"**.

- C. Play shall be suspended whenever the umpire leaves his proper position to clean the home plate / strike mat, or to perform other duties not directly connected with the calling of decisions.
- D. The umpire shall suspend play whenever a batter or pitcher steps out of position for a legitimate reason.
- E. The umpire shall not give a call or signal for **"TIME"** when a batter steps out of position after a pitcher has started his delivery motions.
- F. In case of injury, or if some unforeseen incident occurs before a batter hits the ball **"TIME"** shall be called. But, if the ball is hit, then all action continues until all plays in progress have been completed, or all baserunners have stopped at their bases.
- G. Umpires shall not suspend play for any reason, during live ball action, at the request of players, coaches or managers, until all probable actions have been completed.

BE THE BEST YOU CAN BE.



UMPIRE BENEFITS

Upon successful completion of the Slo-Pitch National Umpire testing program, umpires receive the following benefits:

- **Rule Book** • **Logo'd Uniform Hat**
- **Umpire Certificate** • **News Magazines**

- * **PLUS \$5,000,000 Liability & Secondary Accident Insurance for SPN sanctioned tournaments and league play**

*Applies only while in SPN uniform - Insurance coverage commences after the exam has successfully been completed and registration fee has been paid

If you are interested in taking advantage of the umpire services offered and improving your skills and knowledge, contact the Slo-Pitch National Head Office or your Regional Director.

RULE 11. - SCORING

Sec. 1 THE OFFICIAL SCORER is appointed by the tournament manager and shall keep records of each game as outlined in the following rules. He shall have sole authority to make all decisions involving judgement. For example, it is the scorer's responsibility to determine whether a batter's advance to first base is the result of a hit or an error. However, a scorer shall not make a decision which conflicts with the official playing rules or with an umpire's decision. When no assigned official scorer is present, the umpire shall appoint a scorer. If the umpire is unable to appoint a scorer, then the home team scoresheet shall be official.

Sec. 2 THE BOX SCORE:

- A. Each player's name and the position or positions he has played shall be listed in the order in which he batted or would have batted unless he is removed, or the game ends, before his turn to bat.
- B. Each player's batting and fielding record must be tabulated.
 - 1. The first column shall show the number of times each player batted during the game, but no player shall be charged with a turn at bat when:
 - a. He hits a sacrifice fly.
 - b. He is awarded a base on balls.
 - c. He is awarded first base because of obstruction.
 - 2. The second column shall show the number of runs, if any, made by each player.
 - 3. The third column shall show the number of safe hits, if any, made by each player.
 - 4. The fourth column shall show the number of put-outs, if any, made by each player.
 - 5. The fifth column shall show the number of assists, if any, made by each player.
 - 6. The sixth column shall show the number of errors, if any, made by each player.
 - 7. The name of each player inserted into a team's line-up as a substitute player or runner shall be recorded and the subsequent record tabulated.
- C. The score by innings for each team shall follow the tabulated batting and fielding records.

Sec. 3 THE SUMMARY:

- A. The summary shall follow the score by innings.
- B. The summary shall list the following items in this order:
 - 1. The final score.
 - 2. Runs batted in and by whom.
 - 3. Two base hits and by whom hit.
 - 4. Three base hits and by whom hit.
 - 5. Home runs and by whom hit.
 - 6. Sacrifice flies and by whom hit.
 - 7. Double plays and all defensive participants.
 - 8. Triple plays and all defensive participants.
 - 9. Number of runners left on base, including the batter-baserunner.
 - 10. Number of bases on balls given by each pitcher.
 - 11. Number of batters struck out by each pitcher.
 - 12. Number of hits, runs and earned runs allowed by each pitcher.
 - 13. The name of the winning pitcher.
 - 14. The name of the losing pitcher.
 - 15. The number of innings or parts of innings pitched by each pitcher. A part of an inning is determined by the number of outs. One out is one-third inning; two outs are two-thirds of the inning.
 - 16. The length of the game with any unusual delays deducted.
 - 17. The names of the umpires and scorer.

Sec. 4 ALL INDIVIDUAL AND TEAM RECORDS OF ANY TIE OR FORFEITED GAME which has reached or exceeded legal length when added shall become a part of the official team averages except that no pitcher shall be credited with a victory nor charged with a defeat.

Sec. 5 A RUN BATTED IN is a run scored as a result of:

- A. A base hit.
- B. A sacrifice fly (Even if a fielder drops what would have been a sacrifice fly).
- C. A foul fly caught.
- D. An infield put-out or fielder's choice (Unless the run scores during a successful double play or a double play attempt in which the receiving fielder drops the throw which would have completed a double play).
- E. A baserunner forced home because of a base on balls or catcher's obstruction.
- F. A home run and all runs batted in as a result.
- G. A four base award and all runs batted in as a result.

Sec. 6 A BASE HIT is a batted ball that permits the batter-baserunner to reach base safely. Give a base hit:

- A. When a batter-baserunner reaches first base safely on a fair batted ball which is hit with such force, or such slowness, or which takes an unnatural bounce, making it impossible to field the ball with **ORDINARY EFFORT**.
- B. When a fielder unsuccessfully attempts to retire a preceding runner and, in the scorer's judgement, the batter-baserunner would not have been retired at first base by ordinary effort.
- C. When a baserunner is called out for interference for being hit by a batted ball and the batter is awarded first base, credit the batter with a hit (Ref. Rule 8, Sec 3 c)
- D. When a four base award is signaled.

Sec. 7 A BASE HIT SHALL NOT BE SCORED in the following cases:

- A. When a baserunner is forced out by a batted ball, or would have been forced out, except for a fielding error.
- B. When a player fielding a batted ball retires a preceding runner with ordinary effort.
- C. When a fielder fails to retire a preceding runner, and in the scorer's judgement, the batter-baserunner could have been retired, at first base, with ordinary effort.

Sec. 8 THE LENGTH OF A BASE HIT:

- A. Shall be determined by the number of bases the batter advances without the aid of an error, defensive indifference, or as the result of a play being made on another baserunner (fielder's choice). However, if the ball was batted over the fence or out of the park, a home run shall be credited. **NOTE:** When a batter, in attempting to stretch the length of a hit, overslides a base and is touched out, he is not credited with having made that base.
- B. When the batter ends the game with a safe hit which drives in the winning run, he will be credited only with as many bases, on the hit, as are needed to score the winning run, unless it is an over the fence home run. **NOTE:** The batter must also gain, on the hit, as many bases as are necessary to score the winning run to qualify for an extra-base hit (Ref. Rule 4 Sec 5)
- C. When a fielder deliberately contacts or catches a batted ball with any part of the uniform or equipment detached from its proper place on the fielder and the batter is awarded three bases, credit a triple. (Ref. Rule 8, Sec. 6 H Effect)
- D. When a four base award is signaled, the batter shall be credited with a home run (awarded).

Sec. 9 A SACRIFICE FLY IS SCORED when, with less than two outs, the batter scores a runner on a fly ball which is caught, or when an error is committed on what would have been a sacrifice fly.

Sec. 10 PUT OUTS ARE SCORED in the following situations:

- A. A put-out is credited to a fielder each time he:
 - 1. Catches a fly ball or line drive.
 - 2. Catches a thrown ball which retires a batter or baserunner.
 - 3. Touches a baserunner with the ball when the baserunner is off the base to which he is entitled.
 - 4. Is nearest the baserunner declared out for: being hit with a batted ball, running out of a baseline to avoid being touched with the ball, for interference, leaving a base too soon or carrying a bat to first base.
 - 5. Is nearest the batter-baserunner or baserunner who is called out under the profanity rule.
- B. A put-out is credited to the catcher each time a batter is called out:
 - 1. When a third strike is called.
 - 2. When the batter bunts or chops the ball.
 - 3. When the batter bats illegally.
 - 4. When the batter is struck with his own fair batted ball.
 - 5. When a batter fails to bat in correct order.
 - 6. When the batter, or other player, interferes with the catcher.
 - 7. When a batter strikes a batted ball a second time, intentionally, in fair territory.
 - 8. For stepping on the home plate / strike mat.
 - 9. For stepping out of the batter's area.
 - 10. When a batter is called out under the profanity rule.

Sec. 11 ASSISTS ARE CREDITED in the following situations:

- A. To each player who handles the ball in any series of plays which result in the put-out of a baserunner. Only one assist shall be given to any player who handles the ball more than once in any one put-out.
- B. To each player who handles the ball in any series of plays in a manner which would have resulted in a put-out, if an error had not been made by a teammate.
- C. To a player who, by deflecting a batted ball, aids in a put-out.
- D. To each player who handles the ball in a play which results in a baserunner being called out for interference or for running out of the baseline.

Sec. 12 DO NOT CREDIT an assist to a fielder who commits an error after which the baserunner is put out on a subsequent play.

Sec. 13 ERRORS ARE RECORDED in the following situations:

- A. For each player who commits a misplay which prolongs the turn at bat of the batter or the life of the baserunner (**NOTE:** A fielder is only required to make an ordinary effort).
- B. For the fielder who fails to touch the base or runner after receiving the ball in time to retire a baserunner on a force out or when a baserunner is compelled to return to a base.
- C. For the catcher when a batter is awarded first base because of obstruction.
- D. For the fielder when a baserunner advances a base because of his failure to stop, or try to stop, a ball thrown accurately to a base, unless there was no reason for the throw. When more than one fielder could have received the throw, the scorer must determine which fielder gets the error.
- E. For the fielder who fails to complete a double play because of dropping the ball.
- F. For the fielder who is charged with obstruction.

Sec. 14 ERRORS ARE NOT CHARGED against fielders in the following situations:

- A. When a fielder makes a wild throw in an attempt to prevent a baserunner from advancing, unless the baserunner is able to advance one or more bases beyond the one he would have reached had the throw not been wild, or to a base beyond the one he was forced to.

Example: Runner on first base when the batter singles to right field, runner gains second and attempts to advance to third. Right fielder commits a wild throw to third, but runner stops at third – no error. If the runner scores, show the advance from third to home as a fielder error.

- B. When a fielder drops a fly ball, line drive, or a thrown ball, and recovers the ball in time for a put-out at any base.
- C. Do not charge a mental error except in Sec. 13 B

Sec. 15 A PITCHER SHALL BE CREDITED WITH A WIN in the following situations:

- A. When he is the starting pitcher and has pitched at least four innings and his team was not only in the lead when he is replaced but remains in the lead the remainder of the game.
- B. When a game is ended after four innings of play and the starting pitcher has pitched at least three innings and his team scores more runs than the other when the game is terminated.
- C. As a relief pitcher, if he is the pitcher of record when his team assumes the lead and the lead is maintained to the end of the game.

Sec. 16 A PITCHER SHALL BE CHARGED WITH A LOSS regardless of the number of innings he has pitched if he is replaced when his team is behind in the score, and his team thereafter fails to tie the score or to gain the lead.

Sec. 17 A STATISTICIAN MAY BE APPOINTED BY THE TOURNAMENT DIRECTOR who should maintain an accumulative record of all batting, fielding and pitching records specified for every player who appears in a championship game.

EFFECT Sec. 17 The statistician should prepare a tabulated report at the end of the tournament and submit this report to the tournament director. This report should identify each player by his first name and surname, and position(s) played and should indicate as to each batter whether he bats right handed, left handed or both ways.

Sec. 18 TO COMPUTE AND DETERMINE PERCENTAGE RECORDS

- A. To determine the percentage games won or lost, divide the number of games won by the total number of games won or lost.
- B. For batting average, divide the total number of safe hits by the total times at bat.
- C. For slugging percentage, divide the total bases of all safe hits by the total times at bat.
- D. For fielding average, divide the total put-outs and assists by the total of all put-outs, assists and errors (which are the total chances).
- E. For the pitcher's earned run average, multiply total earned runs charged to his pitching by seven and divide this result by the total of innings pitched. (If a regulation 9 inning game is a tournament requirement, multiply earned runs X 9 and divide by innings pitched.)

Sec. 19 TO ASSURE UNIFORMITY IN ESTABLISHING BATTING, PITCHING AND FIELDING CHAMPIONSHIPS, SUCH CHAMPIONS SHALL MEET THE FOLLOWING MINIMUM PERFORMANCE STANDARDS.

- A. The individual batting champion shall be the batter with the highest percentage average, provided he is credited with as many total appearances at the plate as the number of games scheduled for his team in the tournament, multiplied by 2.5.

EXAMPLE: On 10 games scheduled, 10×2.5 equals 25.00 or more plate appearances required to be considered for the batting championship. Total appearances at the plate shall include official times at bat, plus bases on balls, sacrifice flies, and times awarded first base because of obstruction.

- B. The individual fielding champions shall be the fielders with the highest fielding average at each position.
 - 1. As a fielder, he must have participated at his position in at least two-thirds of the number of games scheduled for his team in the tournament.
 - 2. As a pitcher he must have pitched at least as many innings as the number of games scheduled for his team in the tournament, minimum 12 innings.
- C. The individual pitching champion shall be decided by the lowest earned run percentage, provided that he has pitched at least 12 innings.

RULE 12. - YOUTH PROGRAM

The following are the recommended guidelines for a Youth Program National Tournament. This is not offered at the present time.

Sec. 1 THE YOUTH PROGRAM Will be divided into the following age classifications: Any boy who before August 1st or any girl who before September 1st reaches the below listed birthday is not eligible to participate in that category.

Pee Wee10 years old and underEleventh Birthday
Bantam12 years old and underThirteenth Birthday
Midget15 years old and underSixteenth Birthday
Junior18 years old and underNineteenth Birthday

Sec. 2 Any player can play in a higher age classification but cannot play in a lower age group.

Sec. 3 Players cannot play in more than one age group in the same area at the same time.

Sec. 4 The Youth program is designed for both girls and boys.

Sec. 5 Youth program field dimensions:

Category	Pitching	Base Path	Playing Field Radius
Boys Pee Wee	40'	65'	200'
Girls Pee Wee	35'	55'	200'
Coed Pee Wee	40'	65'	200'
Boys Bantam	40'	65'	200'
Girls Bantam	40'	65'	200'
Coed Bantam	40'	65'	200'
Boys Midget	46'	65'	275'
Girls Midget	46'	65'	225'
Coed Midget	46'	65'	275'
Boys Junior	46'	65'	275'
Girls Junior	46'	65'	225'
Coed Junior	46'	65'	275'

Sec. 6 The catcher must wear a mask (optional in boys junior category) and it is strongly recommended to wear a chest protector.

Sec. 7 The Youth Program will use an official 11 inch, C.O.R. not to exceed .48, stitched softball in all Slo-Pitch National sanctioned tournaments.

Sec. 8 RE-ENTRY: Any of the starting players may withdraw and re-enter once, provided such player occupies the same batting position whenever he is in the line-up. A substitute who is withdrawn may not re-enter.

Sec. 9 Numbers on all uniforms will be required at National, International and World tournaments.

Sec. 10 All playing rules not specifically covered in Rule 12 of this book shall be governed by the other rules as outlined in Rule 1 through 11 of this book.

RULE 13. - COED PROGRAM

Sec. 1 BATTING ORDER 6-4 introduced in 2015; SIX (6) male and FOUR (4) female players will be considered a "normal" lineup.

- A. A female may be substituted for a male and a male may be legally substituted or re-entered into that position in the batting order.
- B. Must always have a minimum of four (4) females defensively and offensively and a maximum of six (6) males defensively.
- C. If an unlimited batting order is used in Coed 5-5, there must be an equal number of males and females in the batting line-up at all times. A 6-4 team may become a 7-5, 8-6 etc.

Sec. 2 FIELD AND EQUIPMENT

- A. All teams should have at least matching tops.
- B. Pitching zone to be fifty (50) to sixty-five (65) feet from point of the original home plate.
- C. In a big ball small ball event, the female will only hit the 11-inch ball and the male will only hit the 12-inch ball. The 12-inch ball will be used in the regular single ball events.

EFFECT Sec. 2 C In a big ball, small ball event, if a batter hits the wrong ball, the play will stand.

- D. Baselines will be 65 feet.

Sec. 3 BATTER-BASERUNNER – A WALK If a male batter is walked intentionally or otherwise, he will be awarded first base. If followed in the batting order by a female, the male batter will be awarded first and second bases. The female **MUST** bat. If an incorrect batter is standing in the on deck position, indicating he or she is the next batter, a male batter that is walked goes to first base only (Ref. Rule 7, Sec 5).

Sec. 4 BASERUNNING

- A. There is to be no sliding while attempting to touch and/or cross the scoring line at any time.

EFFECT Sec. 4 A A player is to be called out if he or she slides while attempting to touch and/or cross the scoring line at the home plate / strike mat.

- B. Sliding may occur at all other bases.
- C. A baserunner who touches the **COMMITMENT LINE** or makes contact with the ground past the **COMMITMENT LINE** with any part of the body between third base and the home plate / strike mat must continue on towards the scoring line (located at the home plate / strike mat).

EFFECT Sec. 4 C A player who has touched and/or crossed over the commitment line as described above and attempts to return to third base, shall be declared out. The ball is alive and all baserunners are in jeopardy.

- D. A baserunner may be tagged out between the commitment line and the scoring line.
- E. All baserunners attempting to score a run must do so by touching the **SCORING LINE** with one foot or by placing one foot on the ground past the **SCORING LINE** in foul territory, in order for it to be counted as a run.

EFFECT Sec. 4 E Runners are out if they touch the home plate / strike mat or cross over the home plate / strike mat in fair territory, whether a play is made or not.

- F. The baserunner should avoid all collisions or be subject to ejection, based on the umpire's judgement.
- G. **COURTESY RUNNERS** may be used (provided the batter has safely reached base) a maximum of three (3) times per game. Only players listed on the line-up card are eligible to be courtesy runners, but the same runner cannot be used more than once. A courtesy runner can be used for a courtesy runner. If there are no courtesy runners or substitutes available to take the place of a courtesy runner that is on base when that player is to be up to bat, an out shall be declared.
- NOTE:** Where a courtesy runner is used, a male must be placed for a male, a female for a female, or a female for a male.

Sec. 5 CATEGORIES OF PLAY

For suggested categories of play see "Sanctioned Tournament Guidelines and Operating Rules".

Sec. 6 OTHER RULES All playing rules not specifically covered in Rule 13 of this book shall be governed by the other rules outlined in Rules 1 through 11 of this book.



**NORTHERN
SHOOTOUT**

Orillia, Ontario • June 24-26, 2016

9th Annual Open / Invitational

**Host of the 2016 Mens A & Womens A
SPN National Championships**

- \$15,000 in Cash & Prizes
- Top Quality Diamonds
- Sponsor Provided Bats
- Mens Home Run Contest
- MVP Awards

Contact Tony Carnelos • tony@homerunsports.com



HR
HOME RUN SPORTS

RULE 14. - MASTERS/SENIORS PROGRAM

Sec. 1 AGE REQUIREMENTS - MENS, WOMENS, COED

A. Minimum age for the **MENS MASTERS 35+** program will be 35 years (effective 2015 National Championships).

Mens MASTERS 35+A/B, 35+C, 35+D and 35+E, effective 2015 National Championships.

B. Minimum age for the **MENS SENIORS 50+, 55+, 60+ and 65+** program will be 50, 55, 60, and 65 years of age respectively.

C. Minimum age for the **WOMENS MASTERS** program will be 35 years.

D. Minimum age for the **WOMENS SENIORS** program will be 50 years. However, five (5) players on the waiver/roster may be a minimum age of 45 years.

E. No more than 4 players listed on a currently ranked A team shall play on any Masters or Seniors A/B team.

NOTE: Players who reach the program minimum age requirement during the calendar year would be eligible to play.

Sec. 2 COURTESY RUNNERS

A. A maximum of seven (7) courtesy runners per game may be used, but cannot use the same runner twice. The courtesy runner can be anyone listed on the line-up card, but the same runner cannot be used more than once.

B. Only players listed on the line-up card are eligible to be courtesy runners. A courtesy runner can be used for a courtesy runner. If there are no courtesy runners or substitutes available to take the place of a courtesy runner that is on base when that player is to be up to bat, an out shall be declared.

C. Seniors 60+ and 65+ can have unlimited use of courtesy runners with no penalty. The courtesy runner can be anyone listed on the lineup card and the same runner can be used more than once.

Sec. 3 BASERUNNING

A. There is to be no sliding while attempting to touch and/or cross the scoring line at any time.

EFFECT Sec. 3 A A player is to be called out if he slides while attempting to touch and/or cross the scoring line (at the home plate / strike mat).

B. Sliding may occur at all other bases.

C. A baserunner who touches the **COMMITMENT LINE** or makes contact with the ground past the **COMMITMENT LINE** with any part of the body between third base and the home plate / strike mat must continue on towards the scoring line (located at the home plate / strike mat).

EFFECT Sec. 3 C A player, who has touched and/or crossed the commitment line, as described above, and attempts to return to third base, the baserunner is out, the ball is alive and all other baserunners continue to be in jeopardy.

D. A baserunner may be tagged out between the **COMMITMENT LINE** and the **SCORING LINE**.

E. All baserunners attempting to score a run must do so by touching the **SCORING LINE** with one foot or by placing one foot on the ground past the **SCORING LINE** in foul territory, in order for it to be counted as a run.

EFFECT Sec. 3 E Runners are out if they touch home plate or cross over the home plate / strike mat in fair territory, whether a play is made or not.

F. The baserunner should avoid all collisions or be subject to ejection, based on the umpire's judgement.

Sec. 4 In all SPN divisions, a 6 run rule will be used in each inning except when an inning is declared an "open inning" by the umpire.

Sec. 5 All playing rules not specifically covered in Rule 14 of this book shall be governed by other rules as outlined in Rule 1 through 11 of this book.

SLO-PITCH NATIONAL - "STG&OR"

SANCTIONED TOURNAMENT GUIDELINES AND OPERATING RULES

All participants registered with Slo-Pitch National shall be considered members. All members agree, through participation, to accept the rules set forth by Slo-Pitch National in this rulebook.

Sec. 1 PENALTIES, SUSPENSIONS AND EJECTIONS

A. Player and/or team member and umpires penalties, suspensions and ejections:

1. Falsification of records:

Deliberate attempt to impersonate a valid team member by a non-member; use of illegal, ineligible or fraudulently represented players; attempted fraud; NSF cheques; purposely applying to a tournament in an improper or lower division.

PENALTY: All team members, including players, coaches and managers are considered responsible and may be held liable for any of the above.

Minimum suspension 1 year, maximum 5 years suspension.

2. Verbal Abuse to Slo-Pitch National and/or its personnel, tournament administrative personnel, officials or host.

PENALTY: Minimum 30 days suspension, maximum 5 years suspension.

3. Physical abuse to Slo-Pitch National and/or its personnel, tournament administrative personnel, officials or host.

PENALTY: Minimum 30 days suspension, maximum 5 years suspension.

4. Unsportsmanlike Conduct to Slo-Pitch National and/or its personnel, tournament administrative personnel, officials or host.

PENALTY: Minimum 30 days suspension, maximum 5 years suspension.

5. Any conduct considered by SPN to be detrimental to the sport of slo-pitch softball or the Slo-Pitch National organization and its personnel.

PENALTY: Minimum 30 days suspension, maximum 5 years suspension.

6. Any misuse to diamonds, surrounding facilities or accommodation facilities.

PENALTY: Minimum 30 days suspension, maximum 5 years suspension.

7. ALL PENALTIES, SUSPENSIONS AND EJECTIONS MAY BE SUBJECT TO REVIEW BY THE SPN NATIONAL DIRECTORS AND MAXIMUMS MAY BE EXTENDED DEPENDING UPON SEVERITY OF THE CASE.

8. SLO-PITCH NATIONAL MAY UPHOLD SUSPENSIONS WHEN REQUESTED TO DO SO IN WRITING, WITH JUSTIFICATION, BY THE EXECUTIVE OF A FULLY AFFILIATED MEMBER LEAGUE, OR OF A RECOGNIZED SLO-PITCH AND/OR SOFTBALL ORGANIZATION. SLO-PITCH NATIONAL DOES NOT RENDER PENALTIES AND OR SUSPENSION DECISIONS FOR LEAGUES.

9. ALL TEAM MEMBERS, INCLUDING PLAYER, COACHES AND MANAGERS ARE CONSIDERED RESPONSIBLE AND MAY BE HELD LIABLE FOR ANY OF THE ABOVE.

B. Team suspensions: The tournament committee may disqualify any team, without compensation, (and put in last place for that division) from the tournament for:

i) Using ineligible or a fraudulently represented player; cheating, attempting fraud; NSF cheques or any other flagrant act(s) that may make a mockery of the game and/or the tournament.

ii) Abuse (verbal or otherwise) to umpires, conveners, organizers or executive members of the tournament, the organizing committee, SPN or the tournament sponsor(s).

iii) Using players who do not meet regional residency requirements or using players who do not meet eligibility requirements.

iv) Falsification of records or deliberate attempt to impersonate a valid team member by a non-member.

PENALTY: All team members, including players, coaches and managers are considered responsible and may be held liable for any of the above.

NOTE: I.D.'S MAY BE CHECKED AT ANY TIME, WITHOUT A PROTEST, BY THE TOURNAMENT COMMITTEE OR THEIR REPRESENTATIVES. If no I.D. (satisfactory as in player eligibility (Sec. 2-D)) is produced, the player may be considered ineligible or fraudulently represented and the team is subject to immediate dismissal from the tournament without compensation. The team will also be ranked last in the tournament standings, and all awards and travel expenses will be confiscated.

When a team is disqualified after a championship has been completed:

i) Final standings will not be adjusted ii) Tournament awards will not be adjusted, iii) Any issued award MUST be returned.

C. Slo-Pitch National shall have the right to suspend any person, team member, including players, coaches and managers or any full team or group in the event that any such person(s) engage in any action, threatened legal action, or conduct that Slo-Pitch National at its discretion shall deem to be detrimental to Slo-Pitch National and its members and the purposes of Slo-Pitch National whether or not such matters occur in connection with any tournament or game situation.

D. If a player or team has been disqualified from the event, all members must leave the event/facility/headquarters immediately for the duration of the event.

E. Any individual suspended from Slo-Pitch National shall not attend a Slo-Pitch National event in any capacity.

F. Ejections: Any team member(s), coach(es), player(s) or scorekeeper(s) ejected from a game by an umpire, for any reason, shall automatically be suspended for his (her) next scheduled game. His (her) actions will be reviewed by the tournament committee for further possible penalties or sanctions.

G. Should any team member, player, coach or scorekeeper, ejected from a game, refuse to leave the park at the requested time, and direct profanity and abuse at the umpire or SPN official, the offender(s) will receive an additional 3 game suspension, subject to a full review.

Sec. 2 PLAYER ELIGIBILITY

NOTE: Slo-Pitch National reserves the right to refuse any application for membership of any person or group that in Slo-Pitch National's discretion, has, by past conduct or activities, brought into disrepute the sport of Slo-Pitch or is likely to cause future harm to the sport either directly or indirectly.

A. Players in good standing may compete on a registered eligible team's waiver/roster in Slo-Pitch National sanctioned tournaments as per guidelines below:

- i) Players may compete in Coed Program, Industrial Program, Masters/Seniors Program and Mens or Womens single sex program (one category per sanctioned event).
- ii) A player wishing to compete in more than one program, as above, **MUST** be registered on the established waiver/roster for the team with which they wish to compete.

EXAMPLE: A player **MAY** compete, on one Master/Seniors team **AND** on one Coed team **AND** on one single sex (Mens or Womens) team in the same sanctioned event, if registered as per "i" above; **HOWEVER**, a player may **NOT** compete in different categories of the same division or program. (**EXAMPLE:** A player may **NOT** compete in Master 35+ **AND** Masters 40 +, **NOR** may a player compete in single sex (Mens/Womens) "A" and "C" **NOR** may a player compete in Coed "B" and in Coed "E")

iii) Players may not officiate at National Championships, in which they are playing.

B. Coed Program players must adhere to categories of play as indicated in Sec. 7 of "Sanctioned Tournament Guidelines and Operating Rules". Masters Coed players must adhere to age requirements as indicated in Rule 14 of the rule book.

C. Masters/Senior Program players must adhere to age requirements as indicated in Rule 14 of the rule book.

D. PLAYERS MAY BE REQUESTED TO PROVIDE PROOF OF IDENTITY. SUFFICIENT PROOF OF IDENTITY MAY BE TWO PIECES OF IDENTIFICATION (ONE OF WHICH SHOULD HAVE A PHOTOGRAPH ATTACHED) BOTH BEARING PLAYER SIGNATURE FOR COMPARISON PURPOSES. THESE TWO PIECES OF IDENTIFICATION SHOULD BE RECENT WITH THE PLAYER'S CURRENT NAME AS USED ON LEGAL DOCUMENTATION.

NOTE: THE TOURNAMENT COMMITTEE MAY, AT ITS DISCRETION, ACCEPT VISUAL VERIFICATION OF IDENTITY FROM SLO-PITCH NATIONAL RECOGNIZED PERSONNEL AS PROOF OF IDENTITY IN EXCEPTIONAL CIRCUMSTANCES ONLY AND WHERE THE PLAYER IS UNABLE TO PRODUCE TWO PIECES OF IDENTIFICATION AS DEFINED ABOVE WITH REASON ACCEPTABLE TO TOURNAMENT COMMITTEE.

E. Industrial program players must be full time employees of the company represented by the team and have been employed full time for at least 60 continuous days prior to the tournament date.

NOTE: National office will consider request for "full-time/part-time" employees if a letter of request is received 45 days prior to tournament start date.

F. Players must be full-time residents of Canada minimum one year prior to tournament start date.

G. Players must be full-time residents of the region in which a team affiliates.

EXCEPTIONS: Players who register with a team through a league which allows players from another region to participate in that league's activities due to league work/residency rules, may be allowed to compete in Slo-Pitch National events with that league-registered team only. Players who qualify in a province, but move to another province, may compete with the team they originally qualified with.

H. Players must be listed on the Slo-Pitch National approved waiver/roster for that team.

I. **SOME REGIONS MAY HAVE A PLAYER RESIDENCY RESTRICTION. CHECK WITH YOUR REGIONAL DIRECTOR OR DISTRICT COORDINATOR BEFORE REGISTERING A TEAM.**

J. **MINIMUM AGE:** A player must be 18 years of age to participate.

EXCEPTIONS: The Regional Director will consider any request for under age players. For safety reasons, no exceptions will be considered for players under 16 years of age.

Sec. 3 NATIONAL CHAMPIONSHIPS

- A. The top 2 finishing teams in each division of the National Championships shall automatically earn a berth to the following year's National Championships, provided that they have participated in one or more regional tournaments or their Region's Provincial Championships.
- B. A team that qualifies for a National Championship is only allowed to add four (4) players of equal or lower caliber in single sex divisions (Mens or Womens), and five (5) players of equal or lower caliber in Coed divisions. NO TEAM MAY HAVE MORE THAN EIGHTEEN (18) PLAYERS ON A NATIONAL CHAMPIONSHIP TEAM WAIVER/ROSTER.
- C. Waivers/rosters for teams attending a National Championship shall be frozen **June 15** of the current year.
- D. Any player changes to this qualifying waiver/roster must be approved by your Regional Director as being of equal or lower caliber (not greater) to the category in which the team is playing.
- E. All teams competing in the National Championship must be members in good standing for that year and must meet all Slo-Pitch National player eligibility criteria (see also Sec. 2).
- F. Teams competing in National Championships will be responsible for all round trip travel costs to the National Championships plus accommodation, travel and personal expenses while at the National Championships. Teams should book travel arrangements that will allow for them to arrive early to the tournament and return after the tournament has been completed. The tournament committee shall not be responsible for altering the tournament schedule because travel plans were changed and or interrupted for any reason.
- G. Any changes made to the official waiver/roster from the tournament in which the team qualified for the Nationals will be considered eligible for national participation providing these changes have been approved by the Regional Director as being acceptable for that team's caliber/category definition.
- H. Waivered/rostered players must be full time residents of the region in which the qualified team affiliates.
- I. A team may only qualify in the region in which it affiliates.

EXCEPTION: In special cases where no qualifier (for a team's registered category) is offered in that team's region, a team may apply for permission to compete in another region's tournament(s) and thereby earn a qualifying berth to represent the region in which the team is affiliated. Permission must be obtained from the Regional Directors of both regions.

- J. National Championships shall be modified round robin format with all teams being scheduled a MINIMUM five games including the championship or elimination round.

NOTE: The tournament convener has the right to modify the tournament format, due to unforeseen circumstances, i.e. inclement weather.

- K. ALL GAMES IN NATIONAL CHAMPIONSHIPS SHALL BE PLAYED UNTIL A WINNER IS DECLARED AND NO TIME LIMIT SHALL BE ENFORCED. IN NATIONAL CHAMPIONSHIP GAMES, THE TIEBREAKER RULE WILL APPLY IN THE 8TH INNING.

- L. Designated allowances for home run hits in fenced fields are as follows:

IN ALL "A" CATEGORIES	7 Home runs Per Team Per Game
IN ALL "B" CATEGORIES	5 Home runs Per Team Per Game
IN ALL "C" CATEGORIES	3 Home runs Per Team Per Game
IN ALL "D" CATEGORIES	2 Home runs Per Team Per Game
IN ALL "E" CATEGORIES	1 Home run Per Team Per Game
IN ALL MASTERS COMP CATEGORIES	5 Home runs Per Team Per Game
IN ALL SENIORS CATEGORIES	2 Home runs Per Team Per Game
COED COMPETITIVE	5 Home runs Per Team Per Game

NOTE: This rule only applies to fenced ball parks and over the fence home runs. Any undeflected ball hit over the fence will be considered a home run as those allowed for that category/division. **PENALTY:** In all above categories, any home run hit in excess of the allowable as shown above, the batter will be called out.

- M. **HOME RUN RULE** (As per Rule 7, Sec. 11)

The following HOME RUN RULE will apply (as stated in "L" above):

- a. In all categories at no time during a game will the number of over the fence home runs hit by one team be in excess of the number allowed for that category/division.

EFFECT Sec. 3M a Where an over the fence home run is hit that is in excess of the number allowed, the batter will be called out.

- b. When a fair fly ball is deflected over the home run fence by a defensive player, the batter-baserunner will be awarded four (4) bases. This will not be considered the same as an over the fence home run.

Sec. 4 PROTESTS

A protested game can result when there is a difference of opinion on the field, between the protesting team and an umpire regarding the application or interpretation of either Official Printed Playing Rules, or Specially Adopted Ground Rule or Specially Adopted Tournament Rules. **PROTESTS WILL NOT BE ACCEPTED IN WHICH UMPIRE'S JUDGEMENT IS QUESTIONED.**

A. **PROTESTS BASED ON MISINTERPRETATION OR MISAPPLICATION OF A TOURNAMENT PLAYING RULE – THE FOLLOWING PROCEDURE IS MANDATORY FOR THE PROTEST TO BE ACCEPTED FOR CONSIDERATION BY THE TOURNAMENT COMMITTEE:**

- a) In tournament play, all protests must be settled before any play can be resumed as a suspended game **except** protests concerning player eligibility.
- b) Any rule protest must be made before the next legal pitch, intentional walk, illegal pitcher action or before all fielders have left fair territory, and must be accompanied by a \$150 protest fee (cash or money order).
- c) The protesting team must advise the plate umpire that the game is under protest, as above, and the plate umpire shall advise the opposing team.
ALL SCORESHEETS MUST BE MARKED AS OF THE "PROTEST POINT"
- d) If the protest is upheld, the game shall resume, from the point of protest, with the protested decision correctly reversed. All players' positions, ball and strike count and game factors to that point shall be resumed according to details as recorded on the officially recognized scoresheet.
- e) If the protest is found invalid, the game shall be resumed from the point of protest as in "d" above, with the protested decision standing as called.

No refund of protest fee will be considered if the protest is found invalid.

B. **PROTESTS BASED ON PLAYER ELIGIBILITY: THE FOLLOWING PROCEDURE IS MANDATORY FOR THE PROTEST TO BE ACCEPTED FOR CONSIDERATION BY THE TOURNAMENT COMMITTEE:**

- a) A formal protest shall be written up and submitted to the tournament protest committee chairman, and must be accompanied by a \$150.00 protest fee (cash or money order).
- b) A formal protest must contain the date, time and place of the game, plus names of the umpires and scorekeeper, plus the pertinent player eligibility section of the Official Rules or Special Printed Playing Rules under which the protest is being filed; plus the decision and/or conditions surrounding the cause for the protest; plus all essential facts involved in the matter of the protest.
- c) A formal protest must contain specific information as outlined above; plus official game ending time (signed by umpire).
- d) Games during which player eligibility is questioned need not be suspended in order to settle the protest.
- e) If player eligibility cannot be resolved at the time of the protest, the game shall be completed.
- f) A formal written protest must be lodged with the Protest Committee at Tournament Headquarters within forty-five (45) minutes of official game ending time (Refer to "c" above) and must be accompanied by a \$150.00 protest fee (cash or money order).

- g) Supporting documentation shall be provided, along with the formal written protest and protest fee, which shall include **FULL (First AND Last) NAME** of player(s) whose eligibility is in question **PLUS** documented proof of the player(s) participation in the game under protest. **DOCUMENTED PROOF MAY CONSIST OF LINE-UP CARD SUBMITTED BY TEAM FOR WHICH THAT PLAYER PLAYED, OR COPY OF OFFICIAL SCORESHEET, WHICH SHOWS FULL NAME OF PLAYER(S) INVOLVED, THAT PLAYERS ACTION IN THE GAME AND THE UMPIRE'S SIGNATURE ON THE DOCUMENT REFLECTING CONFIRMATION OF THAT PLAYER(S) PARTICIPATION IN THE GAME.**
- h) If a team's ineligible player is discovered and verified **during the game**, the offending team loses the game and is eliminated, without compensation, from further play in the tournament.
- i) If a team's ineligible player is discovered *after the completion of the protested game and prior to either teams' next game*, the team deemed to have the ineligible player(s) will be eliminated from further play, without compensation, and the non-offending team will be awarded a win.
- j) If a team's ineligible player(s) is discovered after such time as **either team involved in the protested game has played another game** in the tournament, the offending team shall be eliminated from further play, without compensation, **AT THAT POINT IN THE TOURNAMENT IN WHICH THE DECISION OF INELIGIBILITY IS MADE.**
- k) If the eligibility question cannot be resolved until *after the tournament is completed*, and it is subsequently found that the involved player(s) is ineligible, the team deemed to be at fault shall be placed last in the tournament standings and the standings shall be adjusted accordingly. All awards shall be held in trust until a final decision is made. If awards have been given to the team with an ineligible player(s) they must be returned to the tournament committee within two (2) weeks or further suspensions of up to 3 years may be implemented.

NOTE: IN ALL CASES WHERE A PROTEST IS FOUND VALID AND IS UPHELD, PROTEST FEE SHALL BE REFUNDED (AND SIGNED FOR) AS SOON AS POSSIBLE AFTER THE DECISION IS RENDERED. TEAMS ENTITLED TO REFUND OF PROTEST FEE SHALL CONTACT THE TOURNAMENT PROTEST COMMITTEE CHAIRMAN TO RECEIVE REFUND.

Sec. 5 ROUND ROBIN FORMAT WITH PLUS-MINUS RUN DECIDING FACTOR

In tournament play where a round-robin format determines advancement or placing based on the plus-minus run factor, procedures shall be as follows:

- A. The **MAXIMUM** plus-minus difference, **PER GAME PER TEAM**, is plus seven runs or minus seven runs.

EXAMPLE: The home team is leading 14-0 going into the top of the fifth inning.

The visiting team scores one run in the top of the fifth inning.

i) GAME IS OVER DUE TO THE MERCY RULE

ii) THE PLUS-MINUS FACTOR SHALL ALLOW PLUS SEVEN (+7) RUNS FOR THE HOME TEAM AND MINUS SEVEN (-7) RUNS FOR THE VISITING TEAM.

- B. TOURNAMENT TEAM RANKING CRITERIA FOR PLACING WITHIN EACH POD SHALL BE AS FOLLOWS:

a) Win-loss record.

b) If necessary, win-loss record between tied teams (if all tied teams have played each other).

NOTE: If one team has defeated all the other tied teams, that team will automatically be placed highest of the tied teams. If one team has been defeated by all the other teams, that team will be placed lowest of the tied teams.

c) If all tied teams have not played each other, plus-minus determines finish.

d) If necessary, plus-minus record between tied teams (if all teams have played each other).

e) If necessary, plus-minus record for elimination or championship round if applicable.

f) If necessary, actual score plus-minus differential.

g) If necessary, total runs scored.

h) If necessary, total runs allowed.

i) Revert back in order (Example: if 4 game round robin go to 3rd game, 2nd game, 1st game).

j) If still tied, flip a coin.

NOTE: A PLAY-OFF GAME SHOULD BE HELD FOR THE 3RD AND 4TH POSITION PLACEMENT WHERE FEASIBLE.

Sec. 6 SUSPENDED GAME (reference Rule 4, Sec. 10 EFFECT)

A suspended game can result in tournament play, if the umpire stops play for any reason such as power failure of the lights; protested game in accordance with these rules; any act of God; etc. that precludes immediate continuance of the game, to the conclusion of the full seven innings or as required.

A. In all sanctioned tournament play, the game must go to the complete seven (7) innings.

EFFECT Sec. 6 When a suspended game is resumed, whether it be suspended for one-half hour, one hour, several hours or even to the next day, it must be started at the point of interruption with the identical situations and line-ups as when the game was suspended.

NOTE: The officially recognized scoresheet shall dictate the "**same identical situation**" factors.

Sec. 7 TEAM RATINGS

SLO-PITCH NATIONAL RESERVES THE RIGHT TO MOVE TEAMS INTO HIGHER OR OTHER CATEGORIES IF DEEMED NECESSARY FOR THE BETTERMENT OF THE GAME. TEAMS WILL BE ADVISED BY TELEPHONE OR MAIL IF EFFECTED.

- A. A winner and runner up of a major tournament may be automatically placed into a higher category for Provincial or National Championship play.
- B. Final placement of teams will be determined by Slo-Pitch National for all Regional Qualifiers, Provincial Championships and National Championships.
- C. Teams considered to be "ELITE" calibre, "ALL-STAR" teams or combined teams may be placed in an "OPEN/ELITE" category.

Sec. 8 UNIFORMS (reference Rule 2 – Sec. 9)

- A. While participating in National Tournaments, players **MUST** be uniformly dressed and individual numbers (approximately 4" high, or larger) **MUST** identify each participant.
- B. Managers and coaches **MUST** wear shoes and be uniformly dressed to conform to team uniform with the adopted full uniform or jacket which includes the team's emblem and colours which can readily identify them as a member of the team.

EFFECT Sec. 8 A-B Offending participants will be requested to conform to number and uniform requirements. If they refuse, they will be ejected from the game. This is not a protestable item.

- C. MINIMUM uniform is considered to be matching tops.

Sec. 9 UMPIRES

- A. It is mandatory that all umpires selected to officiate at National Championships be current carded umpires of Slo-Pitch National in good standing. It is mandatory that all umpires selected to officiate Provincial Championships and National Qualifiers also be carded.
- B. All Slo-Pitch National umpires officiating at a Provincial/Regional Championships and National Championship must dress in full current year, regulation SPN uniform from the official SPN supplier. Grey shorts or light grey dress slacks are to be worn.
- C. Umpires may not play at National Championships, if they are acting as an official.

Sec. 10 EQUIPMENT: Slo-Pitch National reserves the right to disapprove any equipment due to the failure to meet either CSA Safety Standards or safety standards as set by the Slo-Pitch National Officiating Committee.

NATIONAL HEAD OFFICE

63 Galaxy Blvd. Unit 4
Etobicoke, ON M9W 5R7
Tel: 416-674-1802 Fax: 416-674-8233
www.slo-pitch.com spn@slo-pitch.com

BOARD OF GOVERNORS

Bill Miller, President
Kent Kamenz, Vice President
Pierre Cadieux, Chairman
Tricia Harrow Rodic, Secretary/Treasurer

SLO-PITCH NATIONAL OFFICIATING COMMITTEE

2016 COMMITTEE CHAIRPERSON

Doug Hadley
2213 - 250th Street
Aldergrove BC V4W 2R5
T: 604-202-6304
F: 604-857-1604
dughadley@shaw.ca

REGIONAL UMPIRE-IN-CHIEFS

BRITISH COLUMBIA

Doug Hadley
2213 - 250th Street
Aldergrove BC V4W 2R5
T: 604-202-6304
F: 604-857-1604
dughadley@shaw.ca

ALBERTA

Clark Wood ("Woody")
403-872-7856
wcwoody64@gmail.com

SASKATCHEWAN

Garry Sciban
90 - 602 Cartwright St
Saskatoon SK S7T 0G5
306-933-1950
gsciban@shaw.ca

MANITOBA

Brian Gagnon
90 Park Place E
Winnipeg MB R3P 1C5
204-632-8067
brian@firstglance.mb.ca

ONTARIO

Peter Leavere
3161 Highway 3
Port Colborne ON L3K 5V3
905-714-6383
pleavere@sympatico.ca

QUÉBEC

Yves Rodrigue
819-846-2111
danyrod10@yahoo.ca

MARITIMES

Ronald Arsenault
63 Braeburn Cres
Moncton NB E1E 2L5
506-384-3658
arsenaulttron@hotmail.com

ATLANTIC

Brian Budden
5 Wellington Cres
Mount Pearl NL A1N 2E1
brianbudden@gov.nl.ca

PACIFIC PERSONNEL

British Columbia & Yukon Territory

REGIONAL OFFICE

#6-11430 201A Street
Maple Ridge BC V2X 0Y4
T: 604-465-5612 F: 604-465-5613
spnbc@slo-pitch.com

REGIONAL DIRECTOR

Jay Tourangeau
c/o SPN Regional Office

REGIONAL ADMINISTRATOR

Lorri McAuley
c/o SPN Regional Office

PROVINCIAL EXECUTIVE

**Mens Director and
Seniors Coordinator**
Andy Maynard
6304 Bradner Road
Bradner BC V4X 2C7
604-856-6143

Womens

Tina Palmiere
18568 64A Avenue
Surrey BC V3S 8S6
604-313-0507
tinapalmiere@shaw.ca

Coed

Gord Shearer
#214 - 520 11th Street
New Westminster BC V3M 5W9
604-764-7367

Members

George Heimbigner
604-588-2399
heim@shaw.ca

Shawn Pritchard

604-217-1097
gocarter@telus.net

AREA DIRECTORS

Kamloops

Drew McLean
250-682-3304
drew@westsydeleague.ca

Kelowna

Chris Jones
250-862-9619
jones4941@shaw.ca

Surrey

George Heimbigner
604-588-2399
heim@shaw.ca

Vernon

Heather Savitsky
250-371-7529
heather.spnvernon@shaw.ca

Victoria

Scott Wood
250-881-7760
scottywood@shaw.ca

Williams Lake

Linda Barbondy
250-392-6643
rowdy22@telus.net

Yukon

George Arcand
T: 867-667-4487 F: 867-667-4237
garcand@northwestel.net

UMPIRE-IN-CHIEF

Doug Hadley
604-202-6304
dughadley@shaw.ca

DEPUTY UMPIRE-IN-CHIEF

Bob Cochrane
604-819-7056
rcochrane4@gmail.com

Educators

Pat Dooley
604-525-2849
ppdooley@shaw.ca

Jason Hodge

604-626-1613
jason.hodge@shaw.ca

Mark Luknowsky

604-845-1199
mluknowsky11@yahoo.ca

Abbotsford

Arlyn Eash
604-300-3475
bcumpy@gmail.com

Aldergrove/Langley

Jim Hodge
3346 273B Street
Aldergrove BC V4W 4A7
T: 604-607-7011 C: 604-617-8487
jimhodge@telus.net

Burnaby/Ladner/North Shore/ Richmond/Vancouver

Joe Leung
604-731-9498
spnjoe@hotmail.com

Burnaby/North Van/Pt. Moody/ Coquitlam/Pt. Coquitlam/Metro

Jack Steele
T: 604-525-5704 C: 604-319-1766

Chilliwack

Bob Cochrane
604-819-7056
rcochrane4@gmail.com

Kamloops

Rick Wile
250-554-2705
rickthebear@hotmail.com

Kelowna

Marvin Ewashko
250-764-7631
kdsua@telus.net

Maple Ridge

Jim Hodge
T: 604-607-7011 C: 604-617-8487
jimhodge@telus.net

Penticton

Jim Charles
250-770-0043
Jimcharles8@gmail.com

Squamish

Daryl C. McCullough
604-892-4842
spiritkeeperdesign@shaw.ca

Surrey

George Heimbigner
T/F: 604-588-2399
heim@shaw.ca

Rusty Monger

604-940-9449
pacificslopitch@dccnet.com

Vancouver Island

Mario Rainaldi
250-727-7692
Bruins44@shaw.ca

Vernon

Chris Lynch
250-549-5109
Clynch_6@hotmail.com

Whistler

Richard Mingotti
604-938-8063
Ricky_mingowhistler@yahoo.ca

Whitehorse

Jean Poulin
T: 867-667-4487 F: 867-667-4237
softball@sportyukon.com

ALBERTA PERSONNEL

REGIONAL OFFICE
c/o Calgary North East
Sports Facility
401 - 33 Street NE
Calgary AB T2A 7R3
T: 403-250-3293
F: 403-250-3215
spnab@slo-pitch.com

Mailing address:
SPN Alberta
PO Box 53190
RPO Marlborough
Calgary AB T2A 7L9

REGIONAL DIRECTOR
Trevor Hauser
c/o Regional Office

PROVINCIAL COORDINATORS
North
Scott Carefoot
780-999-6245
scarefoot@ulterra.com

South
Dean Hanlen
403-617-1640

REGIONAL COORDINATORS
North
Mike Hauck
780-887-1851
mikeh@camionlogistics.com

South
TBA

REGIONAL REPRESENTATIVES
Medicine Hat
Boyd Hamm
403-504-7968/403-622-8014

Red Deer
Wally Vance
403-357-0501
wallyvance@shaw.ca

UMPIRE-IN-CHIEF
Clark Wood ("Woody")
403-872-7856
wcwoody64@gmail.com

DEPUTY UMPIRE-IN-CHIEFS
North
Brent Anderson
780-953-9563

Zone 2 - Red Deer & Area
Bryan Evans
780-667-6523
bevans79@live.com

Zone 3 - Calgary
TBA

Zone 4 - Lethbridge & Area
TBA

ALBERTA ASSIGNERS
Edmonton & Area
Morley Harke
T: 780-464-0128
C: 780-231-0405
mharke@canem.com

Red Deer & Area
Clark Wood ("Woody")
403-872-7856
wcwoody64@gmail.com

Calgary & Area
Tournament Assigner & Umpire Training
Mike Plantz
403-561-2529
micpic_43@yahoo.ca

Tournaments
TBA

Lethbridge & Area
TBA

SASKATCHEWAN PERSONNEL

REGIONAL OFFICE
c/o 214 Scissons Cres
Saskatoon SK S7S 1B8
T/F: 306-956-2255
spnsask@sasktel.net

REGIONAL DIRECTOR
Tony Hnatiuk
c/o Regional Office
C: 306-717-3587
saskrd@sasktel.net

PROGRAM ADMINISTRATOR
Theresa Dmyterko
306-716-8436
tdmyterko@bioriginal.com

PROVINCIAL COORDINATOR
George Dmyterko
538 Highlands Terr
Saskatoon SK S7H 4Y6
306-715-2462
georgedmyterko@sasktel.net

UMPIRE-IN-CHIEF
Garry Sciban
90 - 602 Cartwright St
Saskatoon SK S7T 0G5
306-933-1950
gsciban@shaw.ca

CENTRAL PERSONNEL **Manitoba & Nunavut**

REGIONAL OFFICE

20 De La Seigneurie Blvd
Winnipeg MB R3X 0E9
204-783-1250
spnmanitoba@gmail.com

REGIONAL DIRECTOR

Kent Kamenz
c/o Regional Office
specialk@mymts.net

PROVINCIAL COORDINATOR

Barry Black
bblack27@mts.net

PROGRAM COORDINATOR

Christine Slobodian
c_slobodian@live.ca

AREA COORDINATORS

Winnipeg

Bob St. Laurent
204-654-2255

Darren Neubauer
204-667-2091

Greg Ferguson
204-661-2309

Mens Program
Reece Barthel
Rwbarthel@shaw.ca

Womens Program
Corenna Barthel
corenna@shaw.ca

Thompson
Natasha Anderson
204-307-0595

Thunder Bay
Trish Madigan
807-628-3354

Nunavut
Tracy Cooke
867-979-0745

UMPIRE-IN-CHIEF
Brian Gagnon
90 Park Place E
Winnipeg MB R3P 1C5
204-632-8067
brian@firstglance.mb.ca

DEPUTY UMPIRE-IN-CHIEFS
Gerry Hiebert
204-471-3357
gerryhh@mts.net

Steve Husk
204-981-6772
stevehusk@shaw.ca

Mike Ross
204-391-7335
ross47@hotmail.com

ONTARIO PERSONNEL

REGIONAL OFFICE

63 Galaxy Blvd, Unit 4
Toronto ON M9W 5R7
T: 416-674-1802
F: 416-674-8233
spn@slo-pitch.com
www.slo-pitch.com

REGIONAL DIRECTOR

Bill Miller
c/o Regional Office

PROVINCIAL COORDINATOR
Trish Harrow-Rodic
c/o Regional Office

UMPIRE-IN-CHIEF
Peter Leavere
3161 Highway 3
Port Colborne ON L3K 5V3
905-714-6383
pleavere@sympatico.ca

DEPUTY UMPIRE-IN-CHIEFS
Bob Stagg
519-579-5074
rmstagg@msn.com

Garth Wintle
905-941-3310
nfslopitch@hotmail.ca

ONTARIO PERSONNEL

Ontario - Zone 1

Chatham, Essex, London, Sarnia, Windsor

TOURNAMENT COORDINATORS

Essex County
Laurie Horne-Klassen
519-324-0755
antientropy109@aol.com
Chatham/Blenheim
Gloria Dörner
519-360-6240
gloriadorner@yahoo.ca
London
Lee Ann Hunt
519-680-0834
leeann.hunt@rogers.com

DISTRICT COORDINATORS

Windsor - Coed/Mens
Scott Mahoney
scottmahoney88@hotmail.com
Windsor - Mens
Bruce Ogg
519-566-9739
**Windsor (MicMac/Ciacairo)/
McGregor - Mens/Coed/
Mens Masters**
Dave Renaud
totalpanic8@msn.com
Essex County - Womens
Lisa Magee
519-776-7626
**Essex County - Womens/
Coed**
Dave Pinkney
519-890-7641
Jim Cosgrove
226-350-5593
**Essex County/Windsor -
Mens**
Todd Miller
519-919-4048
John Graham
519-980-3565

**Essex County/Windsor -
Mens Masters**
Aaron Tetreault
519-981-4009
**Essex County/Windsor -
Womens/Coed**
Lea-Anne "L.A." Shepley
519-791-1532
**Essex County/Kingsville -
Mens/Womens/Coed**
Brent Fitzgerald
519-551-3930
Kingsville - Mens
Guy Baltzer
236-345-3311
Kingsville/Wheatley - Mens
Chris Ciliska
519-791-2727
**Harrow/Leamington/
McGregor - Womens**
Crystal Garrod
519-326-0135
**Leamington/Wheatley -
Womens**
Kay Gee
519-562-8783
Chatham-Kent
Billy Hebert
519-676-6824
Cole Abbott
519-401-3452
Chatham-Kent/Blenheim
Tyler Drewery
519-676-4566
**Chatham-Kent/Dutton-
Dunwich**
Steven Laverdure
519-466-1978
**Blenheim/Chatham/Tilbury -
Womens/Mens**
Gloria Dörner
519-360-6240
Lambton/Sarnia
Jason Dickson
519-381-1982

**Lambton County/Sarnia -
Mens**
Mick Jackson
519-332-7442
Elgin County/St Thomas
James Forbes
519-709-7978
St Thomas
Tammy Walker
519-630-8918
**Perth County - St Mary's/
Stratford**
Paul Podsaddecki
519-274-0927
**Oxford County/Tillsonburg/
Woodstock - Womens/Coed**
Kathy Vandervren
519-842-6809
**Oxford County/Tillsonburg/
Woodstock - Mens/Coed**
Darryl Vandervren
519-842-6809

DISTRICT UMPIRE-IN-CHIEFS

Essex
Wayne Ducharme
519-726-0671
**Kent County/Dutton-
Dunwich/London/
Dorchester**
Billy Hebert
519-676-6824
Lambton County - Sarnia
Pat McLaughlin
519-542-5530
London & Area
Shawn Reidy
226-377-0491
Tom Butler
905-531-0854
Dorchester
Rob Glasgow
226-373-4669

Ontario - Zone 2

Kitchener, Hamilton, Niagara Falls

TOURNAMENT COORDINATORS

**Kitchener/Waterloo/
Cambridge**
Mike Condie
519-895-8658
m-condie@rogers.com

Hamilton/Stoney Creek
Kyle Purnell
905-531-4611
zkrp29@hotmail.com

**St.Catharines/Pt. Colborne/
Welland/Niagara-On-The-
Lake/Niagara Falls**
Roger McKee
905-733-0878
rogermckee_88@hotmail.com

ONTARIO PERSONNEL

Ontario - Zone 2

Kitchener, Hamilton, Niagara Falls

DISTRICT COORDINATORS

Kitchener/Waterloo

Brad Schmidt
519-658-3198

Hamilton/Stoney Creek

Kyle Purnell
905-531-4611

ZONE UMPIRE-IN-CHIEF

Bob Stagg

519-579-5074

rmstagg@msn.com

DISTRICT UMPIRE-IN-CHIEFS

Grey/Bruce County

Dean McKeown
519-338-5385

Grey-Bruce County/Kincardine

Chris Turcotte
519-386-7832

Cambridge

Mike Schaefer

519-894-5848

Kitchener/Cambridge

Mike Crane

519-742-7227

Guelph/Wellington/Fergus

Al Hood

519-843-4095

Hamilton/Stoney Creek

Ken Caron

289-439-8207

Beamsville/Grimsby

Wally Kusy

905-563-6098

Niagara Falls/Chippawa/

Niagara-On-The-Lake

Garth Wintle

905-941-3310

Ontario - Zone 3

Mississauga, Toronto, Oshawa, Scarborough

TOURNAMENT COORDINATORS

Mississauga/Etobicoke

Dave Mantell
416-621-7798
dmantell76@hotmail.com

Toronto

Malcolm Murchie
647-988-5283
mmurchie@rogers.com

Durham Region (Ajax/ Pickering/Whitby/Oshawa/ Bowmanville/Port Perry/ Uxbridge)

Lierre Dufresne
905-579-5975
lierre64@rogers.com

DISTRICT COORDINATORS

Milton/Halton Hills

Shawn Campbell
416-557-0097

Oakville/Burlington

Gary Marinacci
905-741-0849

Brampton/Etobicoke

Randy Warren
905-840-7206

Aurora/ Newmarket

Shawn MacPhail
416-559-9120

Markham

Lindsay Stockert
416-892-9356

Durham Region (Ajax/ Pickering)

Alex Clark
416-471-1414
aclark44@gmail.com

Durham Region (Ajax/ Pickering)

Richard McLaughlin
RichardmCL@gmail.com

Durham Region (Bowmanville/Oshawa)

Matt Wright
905-243-2964
matthew.wright28@gmail.com

Durham Region (Women's)

Chantal Houle
416-629-2013
chantal_666@hotmail.com

DISTRICT UMPIRE-IN-CHIEFS

Orangeville

Chris Dryden
519-942-1916

Etobicoke

Karen Kennedy
416-898-3373
karkennedy16@gmail.com

Richmond Hill/Markham

Mike Gorman
705-437-1883

Toronto

Greg Hale
416-694-8283
hammerhale@rogers.com

Tottenham/Beeton/Bradford

Roman Dasek
905-936-4155

Scarborough

Malcolm Murchie
647-988-5283

Scarborough East/Durham Region West (Ajax/ Pickering)

Bruce Knaggs
905-655-8302
bknaggs@rogers.com

Durham Region East (Oshawa/Bowmanville)

Ron Poulton
905-435-8677
rpoulton@hotmail.com

ONTARIO PERSONNEL

Ontario - Zone 4

Peterborough, Kingston, Brockville, Ottawa

TOURNAMENT COORDINATORS

Peterborough

Bill Bowers
705-743-7094
slowbow08@hotmail.com

Belleville/Trenton/Picton/ Napanee

Jamie Cutler
613-813-6156
cutlerace69@hotmail.com

Brockville

Corey Greenwood
613-802-2651
hardcortmlfan@gmail.com

Ottawa/Nepean

Michelle More
613-296-4328
more.michelle@sympatico.ca

DISTRICT COORDINATORS

Peterborough/Kawarthas

Bob Lewis
705-748-3778
Dave Crowley
705-742-1549

Belleville

Sheldon Parent
613-955-9698

Brockville

Tracey Brown
613-498-1440

Ottawa/Nepean

Leo Tardioli
613-783-2000 x202

Ottawa Valley

Chrissy Jolicoeur
613-687-5157
chrissy44@hotmail.com

DISTRICT UMPIRE-IN-CHIEFS

Peterborough

Sal Mastrella
705-931-3232

Brockville/Kingston

Corey Greenwood
613-802-2651

Ottawa

Michelle More
613-296-4328
more.michelle@sympatico.ca

Ottawa Valley

Chrissy Jolicoeur
613-687-5157
chrissy44@hotmail.com

Ontario - Zone 5

Barrie, Orillia, Huntsville, North Bay, Sudbury, Timmins

TOURNAMENT COORDINATORS

Barrie

Ralph Toth
705-737-4096
akasad22@rogers.com

Orillia

Mike Borrelli
T: 705-795-9388
F: 705-329-0882
mikeb9999@hotmail.com

Sudbury

Roger Givoque
705-693-7439
rngivo@persona.ca

DISTRICT COORDINATORS

Timmins

Julie DeMarchi
705-288-5315

ZONE UMPIRE-IN-CHIEF

Pam Mogridge
705-329-0678

DISTRICT UMPIRE-IN-CHIEFS

Barrie/Springwater

Bonnie Branch
705-252-4554

Huntsville/Bracebridge

Wade Wettlaufer
705-788-0969

Sudbury/North Bay/

Espanola

Shawn Bomhower
705-561-8484

Kirkland Lake/Timmins/ Englehart

Angelina Rumble
705-567-1643

QUÉBEC PERSONNEL/ SIEGE SOCIAL QUÉBEC

DIRECTEUR

Pierre Cadieux
Courier: 4215 Rte 222
St. Denis QC J0B 2P0
819-846-4137
pierrecaieux4215@gmail.com

ADMINISTRATION ASSURANCE / REGISTRAIRE COORDONNATRICE

Sylvie Maheux
Courier: 4215 Rte 222
St. Denis QC J0B 2P0
819-578-5798
sylvie.maheux@bell.net

ARBITRE EN CHEF Provincial

Yves Rodrigue
819-846-2111
danyrod10@yahoo.ca

ASS'T ARBITRE EN CHEF Provincial

Guy Rochon
819-684-2240
guyflorochon@videotron.ca

ARBITRES ESTRIE PIF

Yves Rodrigue
819-846-2111
danyrod10@yahoo.ca

Estrie: Tournois

Andre Inkel
dede@abacom.com

Estrie: Ligues

Jacques Lamarche
jacques_lamarche@hotmail.com

Granby Arbitres

Gilles Bradette
gillesetlu@hotmail.com

Gatineau Arbitres

Guy Rochon
guyflorochon@videotron.ca

Administrateur des Tournois Drummondville

Sébastien Deschamps
sebas_deschamps@hotmail.com

Gatineau

Guy Rochon
guyflorochon@videotron.ca

Granby

Shawn Proulx
ssproulx@ca.ibm.com

Rouville

Lucien Paquette
sport-47@hotmail.com

St Constant

Stephane Pigelet
stephanepig@hotmail.com

Responsable Mixte

Alain Morin
mixtebillets.com@hotmail.com

REPRÉSENTANT TOURNOIS/ CADEAUX.

André Inkel
dede@abacom.com

PIF Hommes Semaines

Regis Rioux
rioux.re@videotron.ca

ASS'T PIF Femmes

Annie Houde
annie.houde99@hotmail.ca

PIF Hommes FDS

Pierre Cadieux
pierrecaieux4215@gmail.com

MARITIMES PERSONNEL **New Brunswick, Nova Scotia, P.E.I.**

REGIONAL OFFICE

c/o 1163 Beaver Bank Rd
Beaver Bank NS B4G 1B1
T: 902-864-8027
F: 902-864-5712
slo-pitchmaritimes@hotmail.com

REGIONAL DIRECTOR

Mike Harding
c/o Regional Office

INCIDENT REPORTS FOLLOW UP

Suzanne Allison
PO Box 33
Enfield NS B2T 1C6
T/C: 902-462-6729
B: 902-427-7318
suz_anne_@hotmail.com

WOMENS COORDINATOR

Christina Cooke
902-956-3533
christinacooke5@gmail.com

AREA COORDINATORS - NEW

BRUNSWICK
Saint John
Randy Loatman
334 Duke St W
Saint John NB E2M 1V2
T: 506-214-0833
C: 506-721-8960
dr10fila@hotmail.com

Oromocto
Pierre Chiasson
T: 506-446-4304
C: 506-470-4004
pierre77@nbnet.nb.ca
Moncton
Damien Beaman
506-380-2881
adbeaman@nbnet.nb.ca

Miramichi
Marshall Jenkins
506-623-8056
mandljenkins@sympatico.ca

AREA COORDINATORS - NOVA

SCOTIA
Amherst
Luke Crocker
902-694-8861
luke.a.crocker@gmail.com

Truro

Jason Roberts
902-899-0010
robertsjason78@gmail.com

Yarmouth

Janie Cameron
902-749-1610
beener@eastlink.ca

HRM

Randall Jacquard
48 Raymond Dr
Lower Sackville NS B4C 1H2
902-223-7762
randalljacquard@gmail.com

UMPIRE-IN-CHIEF

Ronald Arsenault
63 Braeburn Cres
Moncton NB E1E 2L5
506-384-3658
arsenaultron@hotmail.com

DEPUTY UMPIRE-IN-CHIEF

Jason MacEachern
C: 902-802-7899/902-401-1238
maceachernjason@hotmail.com

ATLANTIC PERSONNEL **Newfoundland & Labrador**

REGIONAL OFFICE

c/o 16 Smallwood Dr
Mount Pearl NL A1N 1A7
709-691-6993
spnmt.pearl@nl.rogers.com

REGIONAL DIRECTOR

Jack Constantine
c/o Regional Office
709-691-6993

PROVINCIAL COORDINATOR

Kathleen O'Brien
50 Wyatt Blvd
Mount Pearl NL A1N 3H7
709-685-3449
kobrien@corenl.com

DIRECTORS

Avalon
Rob French
26 Castors Dr
Mount Pearl NL A1N 4Y7
709-237-1216
rjfrench@nl.rogers.com

Central

Mary Folkes
25 Cartwright St
Grand Falls NL A2A 1L7
709-489-4081
folkesm69@msn.com

Eastern

Neil Greening
39 Palmers Lane
Clarenville NL A5A 4M6
T: 709-467-1433
C: 709-427-9885
ntgreening@yahoo.com

Gander

Kerry Snook
36 Hobbs St
Gander NL A1V 0E5
709-424-5060
kerrysnook@hotmail.com

Western/Northern Peninsula

Cory Brake
62 Massey Drive
Massey Drive NL A2H 6Z8
709-632-6302
corybrake@hotmail.com

Womens

Bonnie Poole
PO Box 107
Conception Harbour NL A0A 1Z0
709-229-4527
bonitapoole@yahoo.ca

UMPIRE-IN-CHIEF

Brian Budden
5 Wellington Cres
Mount Pearl NL A1N 2E1
brianbudden@gov.nl.ca

DEPUTY UMPIRE-IN-CHIEF

Central
Darren Humber
37A Druken Cres
St. John's NL A0A 1J0
709-293-1239
humber_95@hotmail.com

 **EASTON**

BOMBSQUAD



BOMBSQUAD

COMING SPRING 2016

WWW.EASTON.COM



What does Slo-Pitch National Have to Offer?

For a small fee, teams, leagues, conveners, umpires or individuals may join Slo-Pitch National. Members have many programs and services available to them. Membership has its privileges ... join SPN and receive all of the advantages that go with membership in the largest growing slo-pitch organization in Canada:

- **Tournaments:** The chance to play in all types of tournaments:
 - Provincial and Regional Qualifying Tournaments
 - National Qualifying Tournaments
 - Provincial/Regional Championships
 - National Championships hosted in sites across the country
- **Team Registration:** Mens, Womens, Coed, Masters and Seniors in all calibre levels.
- **League Registration:** Special discounts for full league registration.
- **Ranking:** A current and accurate national team ranking system.
- **Insurance:** A liability and secondary accident insurance policy is available for teams, players, umpires, leagues and conveners.
- **Rule Books:** Current rule books with rules consistent across the country.
- **Umpire's Program:** A complete Umpire's program including carding, insurance, rule book, annual testing,

annual clinics, umpire's manual, casebook, and embroidered umpire's hat.

- **Prize Packages:** Affordable and attractive promotional items available to tournament conveners and leagues.
- **Newsmagazine:** Newsmagazines, with information about slo-pitch events, teams, players, regional updates and news from other countries, as well as other available slo-pitch publications.
- **Fundraising:** Opportunities for teams and leagues.
- **Discounts:** Special pricing / discounts on various sponsor products / services.
- **Internet:** Updated Slo-Pitch information available at our Internet Site **www.slo-pitch.com**
- **Hall of Fame:** SPN recognizes individuals who have played a major role in the growth, development and promotion of slo-pitch softball and SPN.

- **PLUS, PLUS, PLUS:**

All the benefits of belonging to a National slo-pitch organization - direct input (suggestions for rules or program changes are welcome), attendance at the Annual and General Meeting, the chance to be a part of your own slo-pitch organization ... a national organization ... a program administered by experienced slo-pitch people ... an organization that is for all of the people in the game, from "E" calibre to "A" calibre .. plus the opportunity to participate ... as a volunteer, as a player, or as an administrator.

There is something for everyone in the Slo-Pitch National program. To become a part of this organization, contact Head Office or your local Director for more information.

SLO-PITCH NATIONAL - 2016 MEMBERSHIP RATES

Team and League Rates and Application Forms are available on the SPN Website, www.slo-pitch.com or contact your Regional Office or Regional Director.



Insurance Program

SPN Policy term dictates that coverage expires December 31, 2016 for teams, leagues and umpires insured in 2016.

Slo-Pitch National offers various insurance packages for Slo-Pitch activities to teams, leagues, tournament conveners and umpires. Because of league or tournament-operations actions, you are open for possible suit from third parties. You may not be liable but you may need to be defended in court. Protection is available during approved games, practices or team travel as a group. Insured teams or leagues may take advantage of the various benefits included.

The majority of league executives and tournament conveners are volunteers that care about the game and promote the game first. It would be appalling if a good volunteer were sued and wasn't protected under the various insurance programs available. Slo-Pitch National strongly recommends each league or team become a full insured member and take advantage of the added protection available.

LIABILITY

Covers you, as above, from possible suit from third parties. Liability coverage is \$5,000,000 per occurrence.

Note: some maximums and limitations apply. A deductible applies on the liability policy.

SECONDARY ACCIDENT

could pay for such items as: crutches, emergency ambulance/taxi, sound natural teeth, physiotherapy, etc. for which coverage is not already available under your own plan.

This policy is secondary to any existing health plan of which you are already a member (personal or through employers) and also secondary to any government offered plan in your region, whether or not you are a member.

For official insured team members (players, coaches, managers, batboys/girls, scorekeepers) as listed and signed, or electronically accepted, on SPN Official Waiver/Roster Form and umpires.

Some maximums and limitations apply.

PLEASE NOTE

Insurance only applies when you are playing with (and on the SPN waiver/roster of) a team that is insured through Slo-Pitch National. It covers you while playing WITH THAT team and is NOT transferrable.

TEAMS

Available for all Slo-Pitch National sanctioned tournaments and all Slo-Pitch National approved tournaments across Canada and for all games, including league playoffs that the insured team is involved in during league play.

Cost for team liability and Secondary Accident Coverage is included in your insured team registration fee.

LEAGUES

When all teams in the league are insured members of SPN - in this case SPN liability coverage will include league executives for all league games and playoff games.

- Insurance coverage commences upon receipt of paid insured membership by SPN national office, regional director or provincial coordinator.

GROUP TEAM TRAVEL in case teams travel outside Canada. Must be booked in advance. Contact SPN National Office for details.

UMPIRES

Coverage for all games, tournaments and leagues sanctioned/approved by SPN while in an SPN uniform.

Cost of Liability and Secondary Accident coverage is included in umpire membership fee.

- Umpire insurance coverage does not begin until the umpire has passed the test.

Please Note ...

THIS IS NOT A LOSS-OF-WAGE OR INCOME POLICY.

ALCOHOL - If a claim is submitted for secondary accident insurance coverage in which alcohol could be regarded as a contributing factor, this may jeopardize an insurance company(s) approval of such a claim.

ASSAULT - If a lawsuit were to be laid against an insured member as a result of an assault by that insured member then our liability policy would not apply.

DEDUCTIBLE - on our liability policy applies to bodily injury and all expenses.

WAIVER/ROSTER FORM

It is vitally important that the SPN Waiver/Roster form (properly completed and signed, or electronically accepted, by all team members) be returned to the National Office immediately as the National Office must be able to confirm that the injured party is a member of the insured team. The approval of a liability or accident/dental claim could be jeopardized if the National Office does not have a properly completed and signed, or electronically accepted, waiver/roster form when the claim is submitted.



**Congratulations to the following
Slo-Pitch National Hall of Fame Inductees:**

Year	Inductee	Category
2015	Peter McCallum	Umpire
2015	David Grimes	Umpire
2014	Tony Hnatiuk	Builder
2013	Ed Clark	Builder
2013	Molson Coors Canada	Builder
2013	Tricia Harrow-Rodic	Builder
2011	Trevor Hauser	Builder
2009	Greg Ferguson	Builder
2009	Don Brandt	Builder
2009	Jay Tourangeau	Builder
2009	Adam Mordarski	Umpire
2008	Roy Isaacs	Builder

Year	Inductee	Category
2007	John Katerenchuk	Umpire
2007	Ellis Karjala	Builder
2006	Dave Brenton	Builder
2005	Al Moulton	Builder
2005	Chuck Dornier	Coach
2004	Ed Reimer	Umpire/Builder
2002	Paul Langford	Builder
2002	Ross Crocker	Builder
2000	Sharon Sinclair	Umpire
2000	Bill Miller	Builder
1998	Jackie Sheppard	Builder

THIS IS THE CAP

OF PROVING IT AT
EVERY LEVEL.



SPN
SLIP FITTING NATIONAL





**Don't miss your opportunity to qualify
for next year's championships!**

- Compete for the title of National Champions
- Over 8,060 teams have participated since 1989
- Terrific prizes in addition to bragging rights
- Round robin modified double knock out format - unique to this event

A Slo-Pitch Tradition Since 1989



MADE FROM CANADA



PROUD SPONSOR OF SPN

©REGISTERED TRADE MARK OF MOLSON CANADA 2005.